



**VIRGINIO NASTRI S.r.l.**  
Via Seconda Strada, 161 - Z.I. - 36071 ARZIGNANO (VI) ITALY  
Tel. +39 - 0444 450 620 - 451 520 - Fax +39 - 0444 671 840  
E-mail: [info@virginionastri.com](mailto:info@virginionastri.com) - Web Site: [www.virginionastri.com](http://www.virginionastri.com)

# **BELT CONVEYOR CB/M5 Series**

**User and maintenance manual**

## DECLARATION OF CONFORMITY

The company:

VIRGINIO NASTRI S.r.l.  
Via Seconda Strada, 161 - Z.I. - 36071 ARZIGNANO (VI) ITALY  
Tel. +39 - 0444 450 620 - 451 520  
Fax +39 - 0444 671 840

declares under its own responsibility that the machine described below:

Type:	<b>Mod. CB/M5 belt conveyer</b>
Serial n°:	<b>21027/12</b>
Year of production:	<b>2012</b>

is **IN CONFORMITY** with the essential safety requirements dictated:

- **Machines Directive 2006/42/CE**
- **EMC 2004/108/CE**
- **LVD 2006/95/CE**

The following harmonised norms have been applied:

<b>EN 50081 - 2</b>	Electromagnetic compatibility – Generic emission standard - Industrial environment
<b>EN 50082 - 2</b>	Electromagnetic compatibility – Generic immunity standard - Industrial environment

The signer of the declaration is:

Surname:	Virginio
Name:	Domenico
Position in the company:	PRESIDENT of VIRGINIO NASTRI S.r.l.
Place and date:	Arzignano, 28/05/2012
Signature:	

## INSTRUCTION MANUAL INDEX

### INTRODUCTION

P.1	Machine data	Page	4
P.2	How to use and conserve this manual	Page	4
P.3	Safety warnings	Page	5

### SECTION A: GENERAL INFORMATION ON HOW TO USE THE MACHINE SAFELY

A.1	Authorised usage conditions	Page	6
A.2	Information on residue risks and emergency situations	Page	6
A.3	Reference standards and provisions	Page	6

### SECTION B: INFORMATION ON HOW TO USE THE MACHINE

B.1	Machine technical description and layout	Page	7 - 8
B.2	Commands	Page	9
B.3	Regulations	Page	9
B.4	Transportation and installation	Page	10

### SECTION C: INFORMATION ON MAINTENANCE AND REPAIRS

C.1	Maintenance instructions	Page	11 - 12
C.2	Plates and warnings	Page	13
C.3	Spare parts	Page	14
C.4	Wiring diagram	Page	15

### OPTIONALS (IF PRESENT)

O.1	Pallet separator
O.2	Roll separator
O.3	Double roll separator
O.4	Spiral separator
O.5	Side seals
O.6	Electric panel
O.7	Inverter

## INTRODUCTION

### P.1 MACHINE DATA

Manufacturer:

VIRGINIO NASTRI S.r.l.  
 Via Seconda Strada, 161 - Z.I. - 36071 ARZIGNANO (VI) ITALY

Technical data of the CB series belt conveyor (see diagram on Page 8)

Series	CB/M5	
Electric supply voltage (Volt)	400	
Installed power (Kw)	0.22	
<b>DIMENSIONS AND MASS</b>		
Lower flat surface (mm)	700	
Inclined surface (mm)	1700	35°
Useful width (mm)	500	
Total mass (Kg)	126	
Noise level at the user's position dB(A)	< 70	

For technical assistance and information:

VIRGINIO NASTRI S.r.l.  
 Via Seconda Strada, 161 - Z.I. - 36071 ARZIGNANO (VI) ITALY  
 Tel. +39 - 0444 450 620 - 451 520  
 Fax +39 - 0444 671 840

**N.B.:** The user instruction manual is an integral part of the machine itself. Knowledge of the points contained in this manual is essential for safe machine use. This booklet is the Instruction Manual of the previously identified machine and was compiled in accordance with the 89/392 EEC Directive, Annex I, para. 1.7.4

### P.2 HOW TO USE AND CONSERVE THE INSTRUCTION MANUAL

This instruction manual describes machine use as forecasted by design hypothesis, supplies information on how to transport, use, carry out maintenance on and dismantle the machine, and also how to order spare parts.

The instruction manual is a part of the machine and must be kept “for future reference” until final dismantling. It must be conserved in the most opportune manner in the place where the belt is used, and must always be easily reachable.

This manual mirrors the technical state of the machine at the machine marketing date.

VIRGINIO NASTRI srl reserves the right to update production and manuals without the obligation to update previous production and manuals.

A new manual can be requested if the one supplied with the machine is lost or damaged, or if another copy is necessary. When requesting a new copy, please refer to the data given on the CE plate which can be found on the machine.

### **P.3 SAFETY WARNINGS**

In order to ensure maximum working reliability, VIRGINIO NASTRI srl accurately selects the materials and components used to produce the machine, and regularly tests it before shipment. Good machine return through time depends on correct use and suitable maintenance, in accordance with the instructions indicated in this manual.

All the construction elements, as well as the connection and command organs, have been designed and produced with a safety level that permits resistance to stress that is abnormal or at least above those levels indicated in this manual. The materials are of the best quality and their entry into the company, storage and use is constantly controlled in order to guarantee the absence of damage, deterioration and malfunctions.

It should, however, be remembered that:

- 1) THE MACHINE MUST NOT BE USED NOR INTERVENTIONS CARRIED OUT ON IT IF THIS MANUAL AND ALL ITS PARTS HAVE NOT BEEN FULLY READ AND UNDERSTOOD.
- 2) IT IS NECESSARY TO USE ALL THE PRECAUTIONS LISTED IN SECTION A: “SAFETY PRESCRIPTIONS AND INFORMATION”.
- 3) IT IS FORBIDDEN TO USE THE MACHINE IN CONDITIONS OR MANNERS THAT ARE DIFFERENT FROM THOSE INDICATED IN THE MANUAL. VIRGINIO NASTRI SRL CANNOT BE HELD RESPONSIBLE FOR FAULTS, INCONVENIENCES OR INJURY CAUSED BY THE NON-OBSERVANCE OF THIS POINT.

This manual has been divided into three parts:

SECTION A: which looks at “SAFETY PRESCRIPTIONS AND INFORMATION”

SECTION B: in which the MACHINE CHARACTERISTICS – OPERATION – TRANSPORTATION aspects are indicated.

SECTION C: which describes the MAINTENANCE AND LUBRICATION INTERVENTIONS with an annexed LIST AND DESCRIPTION OF THE SPARE PARTS

To make reading easier, the following terms have been used:

#### **DANGER**

The term DANGER is used in situations where not respecting the regulations or tampering with organs can cause serious injury to people.

#### **ATTENTION**

The term ATTENTION is used in situations where not respecting the instructions can damage the machine or other elements associated with it or the surrounding environment.

**SECTION A**

*General information for using the machine safely*

**A.1 AUTHORISED MACHINE USE**

This series of belt conveyors should be used for collecting and transporting plastic parts coming from moulding machines and going towards the accumulation area.

The belt run can be varied and the following adjustments are possible:

- height and belt inclination;

**ATTENTION:**

The maximum weight of the transportable parts must not exceed 70 Kg in total. The belts are not suitable for transporting loose material.

The belt conveyors can be easily used by all the staff of the plant in which it is installed, and if used correctly does not present any risks for the operator.

We recommend reading this manual, however, before using the machine.

VIRGINIO NASTRI srl declines any responsibility in the following cases:

- if the belts are used in evident contrast to the manner indicated in this instruction booklet;
- if there are supply faults;
- if the necessary maintenance is not carried out as indicated;
- if unauthorised modifications are made;
- if unauthorised spare parts or spare parts that are not specifically for the model are used;
- in cases of exceptional events.

**A.2 INFORMATION ON RESIDUE RISKS**

Residue risk: a risk that remains in spite of all the precautions adopted, or a potential risk that is not evident (Directive 89/392/ para. 1.7.2.).

This series of belt conveyors basically does not present residue risks for the operator, as long as the instructions given in this manual are followed. In spite of this, however, the following indications are valid according to usage conditions:

**DANGER:**

Risk of fire: fire can break out if the characteristics of the belt used are not suitable for belt use (in particular: the temperature of the pieces to be transported).

Make sure, therefore, that the type of material used for the transporting surface has adequate characteristics. Refer to the data given in the following table.

Belt material	Max. temperature of pieces
GREEN POLYURETHANE	120° C

Risk of elevated temperatures: the belt should be used to transport pieces that have just been moulded, therefore which are hot. Should it be necessary to intervene, use protective gloves (particularly in the piece falling area).

**A.3 REFERENCE STANDARDS AND PROVISIONS**

- This belt conveyor series was designed and produced to satisfy the Essential Safety requirements as dictated by the 89/392 Directive, Annex I.
- Reference is made to the EN 60204-1 Standard, September 1993 edition, for electric equipment.

## **SECTION B**

### *Information on belt use*

**WARNING:** Before reading this section you must be familiar with what is indicated in section A, an integral part of the user manual and which must be understood for using the machine SAFELY.

#### **B.1 MACHINE TECHNICAL DESCRIPTION AND LAYOUT**

This belt conveyor series is made up of:

A load bearing frame of folded sheet steel. There are containment projections on the sides, and everything is supported by the supplied rods (13). The rods can be adjusted as follows:

- Use the screws (14) to regulate the inclination;
- Remove the screws (16) and use the four legs (17) to regulate the height;

There are 4 casters with a locking device (18) on the base, which makes it possible to move the belt around the working area.

The belt conveyor frame has some supports (4) which hold a drum (5) that rotates. This drum is moved directly by a gearmotor (1-2), which in turn moves the belt (8) forward. The return drum (6) rotates as a consequence of belt movement. The whole system is controlled by a switch (3).

*The noise level issued by the machine at the operator's working place is < 70 dB(A).*

*The switch is equipped with a device (minimum voltage coil) which automatically deactivates the switch when there is no current. This guarantees that the machine does not start unexpectedly when the current returns.*

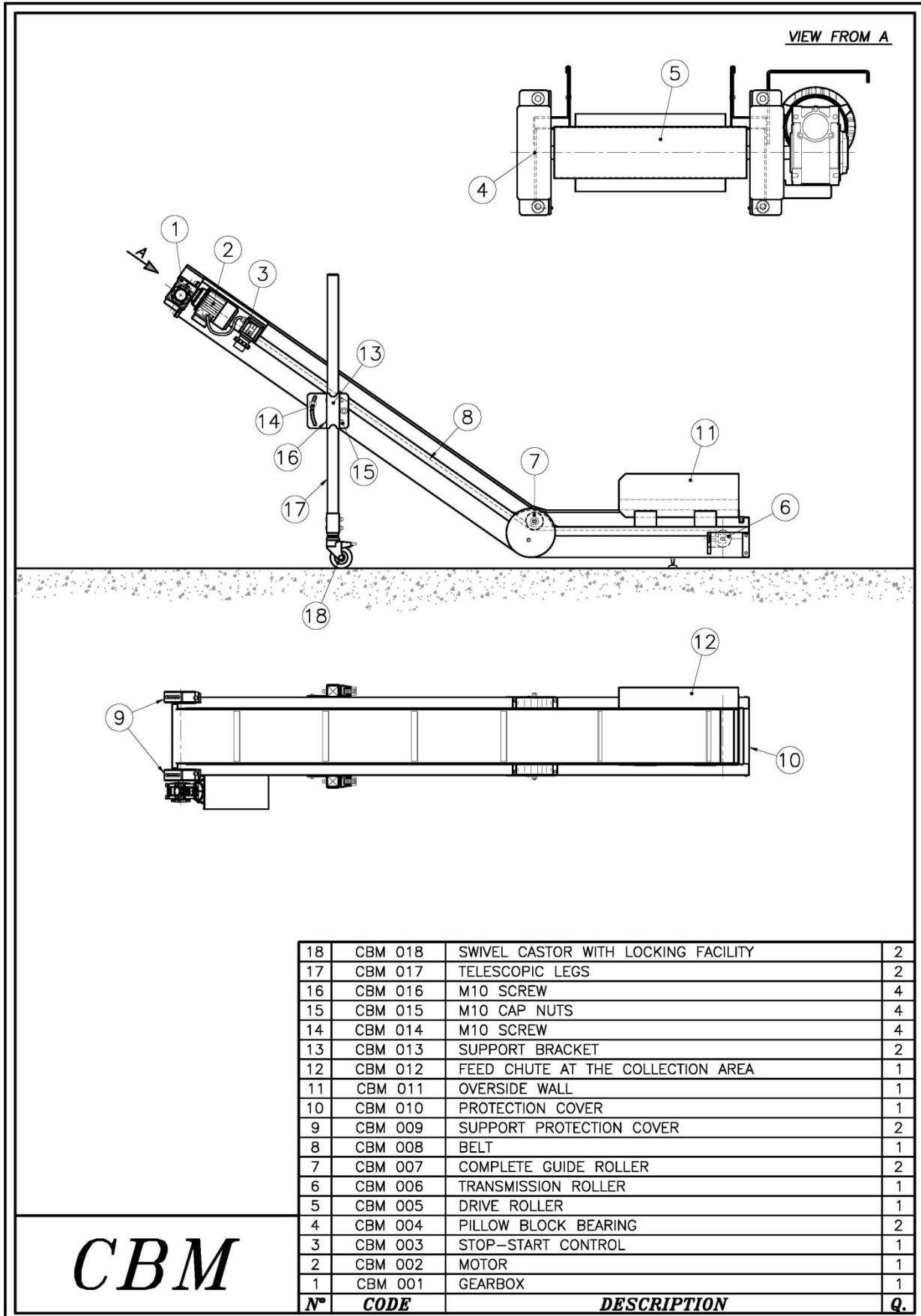



## B.2 COMMANDS

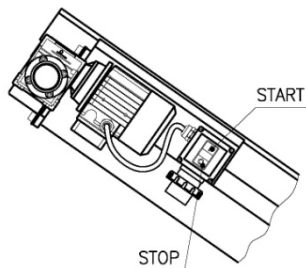

Pic. A

As described in the previous paragraph, the switch with the belt start and stop keys is positioned in the discharge area (pic. A).

**Emergency stop:** whenever necessary, directly disconnect the belt supply plug.

## B.3 REGULATIONS

### Regulating the height of the belt (pic. B).

#### **ATTENTION:**

This operation should be carried out with at least two people working together.

Loosen the bolts (15), extract the screws (16), raise or lower the telescopic legs (17). When the correct height has been reached, insert the screws (16) and tighten the nuts (15).

### Regulating the belt inclination (pic. B)

#### **ATTENTION:**

If the lock nuts are loosened (14) the belt does not remain in equilibrium, because unbalanced by the gearmotor.

This operation should be carried out with at least two people working together. One should support and regulate the belt, the other should loosen and tighten the lock nuts (14).

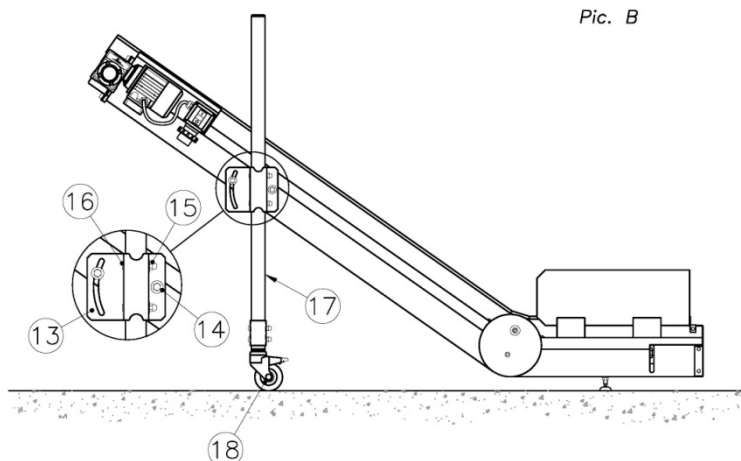

Pic. B

Pic. C

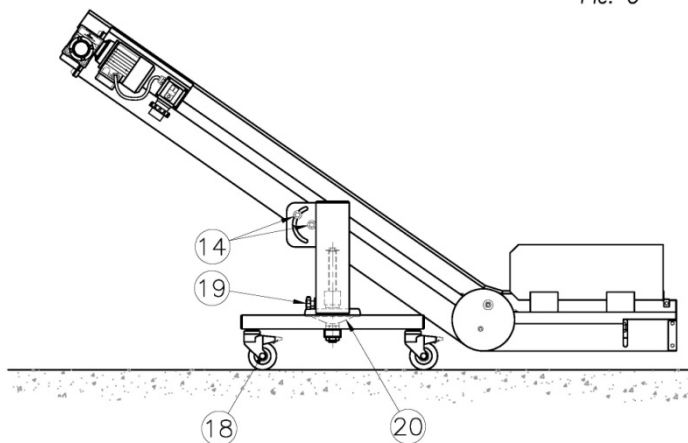

### Adjusting the height of the conveyor with Future stand (pic. C)

Loosen the locking knobs (19), rotate the handwheel (20) to adjust the height, and then tighten the knobs again (19).

### Adjusting the inclination of the conveyor with Future stand (pic C)

#### **ATTENTION:**

If the conveyor is already inclined, it won't remain balanced when the knobs are loosened, because the lower flat surface throws it off balance.

To perform this operation, two operators are necessary: One will support and adjust the conveyor, the other will loosen and later tighten the knobs (14).

## B.4 TRANSPORTATION AND INSTALLATION

### Transportation

Stretch film is used to wrap the belt conveyors. The switch and gearmotor boxes are protected by sponge rubber.

### **ATTENZION**

The packaging material (plastic film and sponge rubber) should not be disposed of in the environment but in accordance with current norms.

The belt conveyors should be raised using a fork lift truck. The overall dimensions and mass of the belts in this series are given in para. P1.

### **DANGER**

For operator safety and machine integrity please refer to pic. D, which shows where to insert the forks in order to raise the belt in a stable manner.

Once on the lorry loading surface, the machine should be fixed using levers to block the wheels. Suitable slings or fixing methods should also be prepared to ensure stability during transportation.

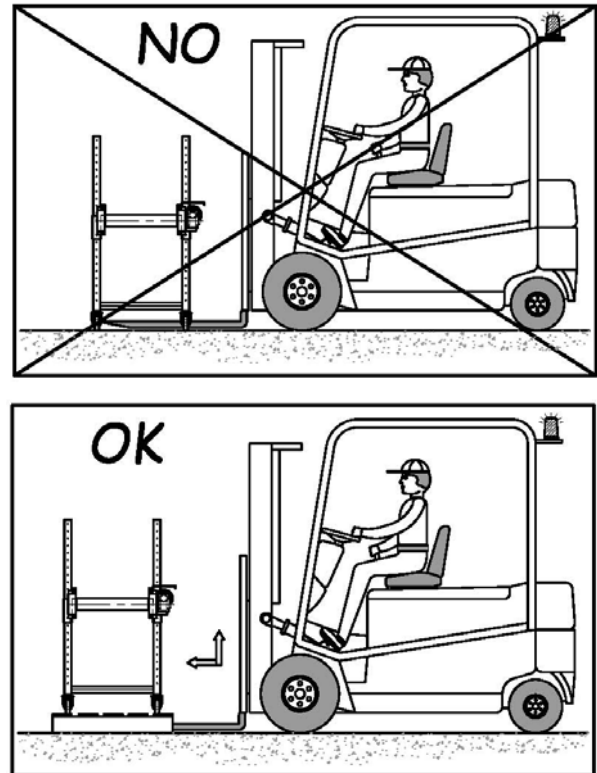

Pic. D

### Installation

No particular preliminary operations are necessary when starting the belt conveyors for the first time.

The belt should be connected to an outlet having suitable characteristics. Use the supplied plug.

When laying the cables, please make sure that they are protected against damage and that they cannot trip the operators.

### **ATTENTION:**

Before starting the belt conveyor:

- make sure that the supply voltage corresponds to the one indicated on the plate. The plate can be found beside the belt button;
- check the correct rotational direction of the motors. Make sure that the belt rotates in the direction indicated by the arrow on the belt casing.

Position the belt conveyor by inserting the lower surface opening (loading area) into the relative opening which passes under the press mould.

### **ATTENTION:**

When the machine has been installed, the casters must be locked using the levers on each wheel.

## **SECTION C**

### *Information on maintenance and repairs*

#### **C.1 MAINTENANCE INSTRUCTIONS**

##### *GENERAL NOTES*

The operator must ensure that the machine is kept clean of foreign material such as deposits, oil or others. The machine should therefore be cleaned at the end of each work shift when it has stopped and is in a stable condition.

##### **ATTENTION:**

Before starting, the operator should switch off the belt and extract the mains plug to avoid any possibility of accidental starting.

If compressed air is used to clean the machine, protective goggles with additional mask should be used. Any people in the surrounding area should also be removed to avoid the danger of being hit and injured by material and dust.

Do not use pressurised water directly on the electric apparatus.

It is forbidden to use flammable liquids for cleaning.

Periodically check the state of the plates and replace them if necessary.

Once the machine has been cleaned, the operator should make sure that there are no parts that are worn or damaged (if there are, immediately request the intervention of the maintenance technician) or parts that are not solidly fixed (do as much as possible).

The operator and possible maintenance technician must wear suitable working clothes that do not fly about, and should not wear chains or bracelets or other items which can catch easily in the moving mechanical organs. Operators with long hair should use a hairnet to prevent the risk of entanglement.

The protection and safety devices must not be removed unless a repair and/or maintenance operation is to be carried out.

These devices must be replaced as soon as the reason for their temporary removal has been corrected, and in any case before the machine is started again.

##### **ATTENTION:**

At the end of each machine intervention, use the relative levers to lock the wheels (18, pic. B-C).

This belt conveyor series does not require particular maintenance operations, just some simple interventions.

Inspect to ensure that:

- the gearmotors are not leaking lubricant;
- the belt is tightened correctly (\*);
- the belt is centred correctly (\*);
- the electric cable insulating sheath is in good condition (every 2000 working hours).

**[\*] ATTENTION:**

Before carrying out this operation the machine must be put out of service. In addition, the plug should be disconnected from the mains after having switched off the belt.

Should it be necessary to regulate the belt, remove the casing at the belt end and use the tension rod regulating nuts. To centre the belt, unscrew the small casing at the belt end, both on the lower part and the inclined part, then use the tension rod regulating nuts. Allow the cloth to turn until it is well centred on the drum (pic. E).

*Pic. E*

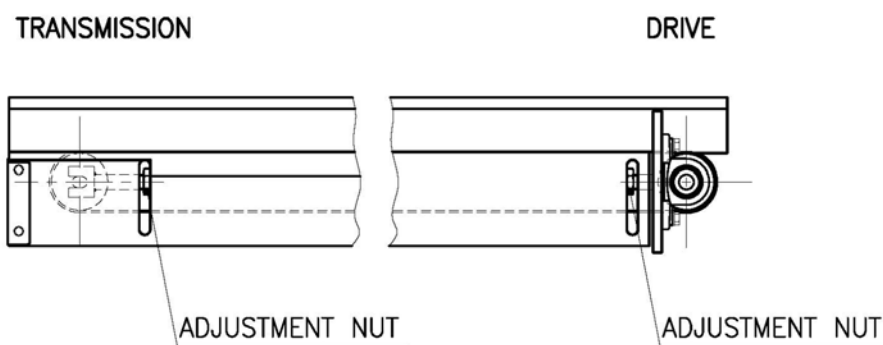

**DANGER:**

The cloth should be turned to check centring. Regulate while the machine is not moving and make the belt turn only for the time necessary for verifying correct cloth centring.

Each month, make sure that the external temperature of the motor and the gearmotor is not too high (lower than 60°C). Should irregularities occur, directly contact VIRGINIO NASTRI srl technicians.

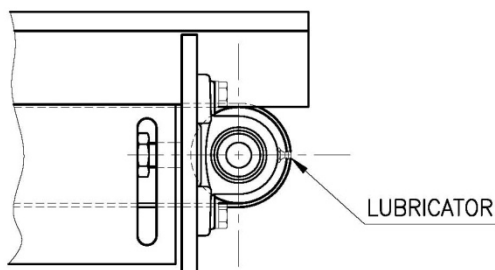

Lubrication:

Every month grease the two supports on the belt discharge section, under the protective casing, as indicated in the diagram (pic. F).

*Pic. F*

## C.2 PLATES AND WARNINGS

The following danger symbol is present on the wrapping of terminal boards that can be powered:

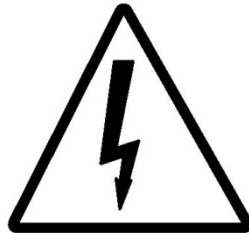

The plate shown below is also present on the belt:

			
Via Seconda strada,161 -Z.I. 36071 Arzignano(Vicenza) - ITALY Tel. ++39.0444.450620-451520 Fax ++39.0444.671840			
MODELLO MODEL	<input type="text"/>		
MATRICOLA SERIAL NUMBER	<input type="text"/>	ANNO COSTRUZIONE YEAR OF MANUFACTURE	<input type="text"/>

### C.3 SPARE PARTS

Should it be necessary to order spare parts, please refer to the address given in para. P1. When ordering, always give the part code and the requested quantity of each part ordered.

Note: Only original spare parts supplied by VIRGINIO NASTRI srl guarantee operation reliability.

It should be noted, in particular, that some components have safety characteristics for the personnel, therefore these pieces should only be replaced with the parts recommended by VIRGINIO NASTRI srl.

#### SPARE PARTS AND RELATIVE CODES

CBM CODE                      VIRGINIO BELT CONVEYORS

<u>CODE</u>	<u>DESCRIPTION</u>
CBM 001	GEARBOX
CBM 002	MOTOR
CBM 003	STOP-START CONTROL 0.6 - 1 A
CBM 004	PILLOW BLOCK BEARING
CBM 005	DRIVE ROLLER
CBM 006	TRANSMISSION ROLLER
CBM 007	COMPLETE GUIDE ROLLER
CBM 008	BELT
CBM 009	SUPPORT PROTECTION COVER
CBM 010	PROTECTION COVER
CBM 011	OVERSIDE WALL
CBM 012	FEED CHUTE AT THE COLLECTION AREA
CBM 013	SUPPORT BRACKET
CBM 014	M10 SCREW
CBM 015	M10 CAP NUTS
CBM 016	M10 SCREW
CBM 017	TELESCOPES
CBM 018	SWIVEL CASTOR WITH LOCKING FACILITY

## C.4 WIRING DIAGRAM

