



VIRGINIO NASTRI srl

Via Seconda Strada,161 - Z.I. - 36071 ARZIGNANO (VI) ITALY

++39-0444 450 620 - ++39-0444 651 520 - Fax ++39-0444 671 840

E-mail: info@virginionastri.com - Web Site: www.virginionastri.com

BELT CONVEYOR CBDS 12 Series

User and maintenance manual

DECLARATION OF CONFORMITY

VIRGINIO NASTRI S.R.L., Via Seconda Strada, 161 - 36071 Arzignano (Vicenza) Italy Tel. +39 - 0444 - 45.06.20, fax +39 - 0444 - 61.18.40

declares under its own responsibility that the following machine:

Type: **Belt conveyor Mod. CBDS/12**

Serial number: **23604/14**

Year of production: **2014**

- is **IN CONFORMITY** with the essential safety requirements dictated by Machines Directive nr. **89/392**, and the variants introduced with the **91/368 – 93/44 – 93/68** Directives
- is **IN CONFORMITY** with the **89/336** and **73/23** Directives.

The following harmonised norms have been applied:

EN 50081 - 2	electromagnetic compatibility – Generic emission standard, part 2 industrial environment
EN 50082 - 2	electromagnetic compatibility – Generic emission standard, part 2 industrial environment
EN 60204 - 1	electrical equipment of machines

The signer of the declaration is:

Surname: **Virginio**

Name: **Domenico**

Position in the company: **PRESIDENT of VIRGINIO NASTRI S.R.L.**

Place and date: **Arzignano, 24/04/2014**

Signature:



INDEX

INTRODUCTION

P.1	Machine information	Page	4
P.2	How to use and keep this manual	Page	4
P.3	Safety warnings	Page	5

SECTION A: GENERAL INFORMATION ON HOW TO USE THE MACHINE SAFELY

A.1	Authorised use	Page	6
A.2	Information on residue risks and emergency situations	Page	6
A.3	Reference standards and provisions	Page	6

SECTION B: INFORMATION ON HOW TO USE THE MACHINE

B.1	Machine technical description and layout	Page	7 – 9
B.2	Commands	Page	10
B.3	Regulations	Page	10
B.4	Transportation and installation	Page	11

SECTION C: INFORMATION ON MAINTENANCE AND REPAIRS

C.1	Maintenance instructions	Page	12 - 13
C.2	Plates and warnings	Page	14
C.3	Spare parts	Page	15
C.4	Wiring diagram	Page	16

OPTIONALS (IF PRESENT)

O.2	Roller separator
O.3	Double roller separator
O.4	Spiral separator
O.5	Hermetic side sealing
O.6	Electric panel
O.7	Inverter

INTRODUCTION

P.1 MACHINE DATA

Producer:

VIRGINIO NASTRI srl

Via Seconda Strada, 161 - Z.I.

36071 ARZIGNANO (VI)

Technical data regarding the CBDS 12 series belt conveyor (see drawing on page 8)

CBDS Series	12
Electric supply voltage (Volt)	400
Installed power (KW)	0.22
DIMENSIONS AND MASS	
Lower surface section (mm)	710
Sloped section (mm)	1800
High surface section (mm)	700
Usable width (mm)	450
Total mass (Kg)	140
Noise level at the operator's position in dB(A)	< 70

For technical assistance and information:

VIRGINIO NASTRI srl

Via Seconda Strada, 161 - Z.I. ARZIGNANO (VI)

Tel. 0444/450620 - 451520

Fax 0444/671840

Nota Bene: The user instruction manual is an integral part of the machine itself. Familiarity with the points contained in this manual is essential for safe machine use. This booklet is the Instruction Manual of the previously identified machine and was compiled in accordance with the EEE 89/392 Directive, Annex I, par.1.7.4

P.2 HOW TO USE AND KEEP THE INSTRUCTION MANUAL

This instruction manual describes machine use as forecasted by design hypothesis, supplies information on how to transport, use, carry out maintenance on and dismantle the machine, and also how to order spare parts.

The instruction manual is a part of the machine and must be kept "for future reference" until final dismantling. It must be kept in the most opportune manner in the place where the belt conveyor is used, and must always be easily reachable.

This manual mirrors the technical state of the machine at the machine marketing date.

VIRGINIO NASTRI srl reserves the right to update production and manuals without the obligation to update previous production and manuals.

A new manual can be requested if the one supplied with the machine is lost or damaged, or if another copy is necessary. When requesting a new copy, please refer to the data given on the CE plate on the machine.

P.3 SAFETY WARNINGS

In order to ensure maximum working reliability, VIRGINIO NASTRI srl accurately selects the materials and components used to produce the machine, which is regularly tested before shipment. Good machine return through time depends on correct use and suitable maintenance, in accordance with the instructions indicated in this manual.

All the construction elements, as well as the connection and command organs, have been designed and produced with a safety level that permits resistance to stress that is abnormal or at least above the levels indicated in this manual. The materials are of the best quality and their entry into the company, their storage and their use is constantly controlled in order to guarantee the absence of damage, deterioration and malfunctions.

It should, however, be remembered that:

- 1) THE MACHINE MUST NOT BE USED NOR INTERVENTIONS CARRIED OUT ON IT IF THIS MANUAL AND ALL ITS PARTS HAVE NOT BEEN FULLY READ AND UNDERSTOOD.
- 2) IT IS NECESSARY TO USE ALL THE PRECAUTIONS LISTED IN SECTION A: “SAFETY PRESCRIPTIONS AND INFORMATION”.
- 3) IT IS FORBIDDEN TO USE THE MACHINE IN CONDITIONS OR MANNERS THAT ARE DIFFERENT FROM THOSE INDICATED IN THE MANUAL. VIRGINIO NASTRI SRL CANNOT BE HELD RESPONSIBLE FOR FAULTS, INCONVENIENCES OR INJURY CAUSED BY THE NON-OBSERVANCE OF THIS POINT.

This manual has been divided into three parts:

SECTION A: which looks at “SAFETY PRESCRIPTIONS AND INFORMATION”

SECTION B: in which the MACHINE CHARACTERISTICS – OPERATION – TRANSPORTATION aspects are indicated.

SECTION C: which describes the MAINTENANCE AND LUBRICATION INTERVENTIONS with an annexed LIST AND DESCRIPTION OF THE SPARE PARTS

To make reading easier, the following terms have been used:

DANGER

The term DANGER is used in situations where not respecting the regulations or tampering with organs can cause serious injury to people.

ATTENTION

The term ATTENTION is used in situations where not respecting the instructions can damage the machine or other elements associated with it or the surrounding environment.

SECTION A

General information on how to use the machine safely

A.1 AUTHORISED MACHINE USE

This series of belt conveyors should be used mainly for the collection and transportation of plastic pieces coming from the moulding machine and going towards the accumulation area.

The belts of this series are equipped with a device for separating the residues (blade separator) installed on the high surface section of the belt.

The belt angle can be varied and the following adjustments are possible:

- belt height and slope regulation;
- blade separator height and angular direction regulation

ATTENTION:

The maximum weight of the goods to be transported should not exceed a total of 70 Kg. The belts are not suitable for moving loose material.

The belt conveyors can be easily used by all people who operate the plant in which they are installed, and if used correctly do not present any risks for the operator.

We recommend reading this manual, however, before using the machine.

VIRGINIO NASTRI srl declines any responsibility in the following cases:

- if the belts are used in evident contrast to the manner indicated in this instruction booklet;
- if there are supply faults;
- if the necessary maintenance is not carried out as indicated;
- if unauthorised modifications are made;
- if unauthorised spare parts or spare parts that are not specifically for the model are used;
- in cases of exceptional events.

A.2 INFORMATION ON RESIDUE RISKS

Residue risk: a risk that remains in spite of all the precautions adopted, or a potential risk that is not evident (Directive 89/392/par.1.7.2.).

This series of belt conveyors does not present residue risks for the operator, as long as the instructions given in this manual are followed. In spite of this, however, the following indications are valid:

DANGER:

Risk of fire: fire can break out if the characteristics of the belt being used are not suitable for the authorised use (in particular the temperature of the pieces to be moved).

Please refer to the data indicated in the table below in order to make sure therefore that the belt is made from material that has suitable characteristics.

Type of cloth	Max. piece temperature
GREEN PU	100° C

Risk of high temperature: the belt is used to transport newly moulded parts, which are hot. Should it be necessary to intervene, use protective gloves (in particular in correspondence with the piece fall point).

A.3 REFERENCE STANDARDS AND PROVISIONS

- The belt conveyors of this series were designed and manufactured to satisfy the Essential Safety requirements as dictated by the 89/392 Directive, Annex I.
- Reference is made to the EN 60204 – 1 Standard, September 1993 edition, for electric equipment.

SECTION B

Information on how to use the belt

WARNING: Before reading this section you must be familiar with what is indicated in section A, an integral part of the user manual which must be understood for using the machine SAFELY.

B.1 MACHINE TECHNICAL DESCRIPTION AND LAYOUT

This series of belt conveyors is made up of:

A support frame of press bent sheet steel with containing rims on the sides, positioned on a support frame (13) that can be regulated as follows:

- by using the screws (14) to regulate the slope;
- by loosening the knobs (15) and rotating the flywheel (16) which runs on a threaded bar (17) to regulate the height.

There are four casters with locking device (18) at the bottom for moving the device around the work area.

A cylinder (5) rotates on the supports (4) of the belt conveyor frame, and the cylinder is moved directly by a gearmotor (1-2). The gearmotor moves the mat (8) forward, activating the return cylinder (6). Everything is controlled by a switch (3).

There is a panel (11) on the side and a chute (12), which collect the transported pieces.

The noise level at the operator's work place is < 70 dB(A).

The blade separator can be regulated in height and the horizontal surface can be orientated. It is also equipped with a brake device that can be regulated and which stops separator rotation in case of interference with the transported objects and/or with the limbs of the operator. Even the blade separator is equipped with a switch (18) with movement command and stop function. The respective switch is mounted together with the belt switch on one side of the upper section of the belt itself. The electric supply of the separator is derived from that of the belt.

Both switches are equipped with a device (minimum voltage coil) which automatically deactivates the switches when there is no line voltage, guaranteeing safety against unexpected restarting of the machine when the power is returned.

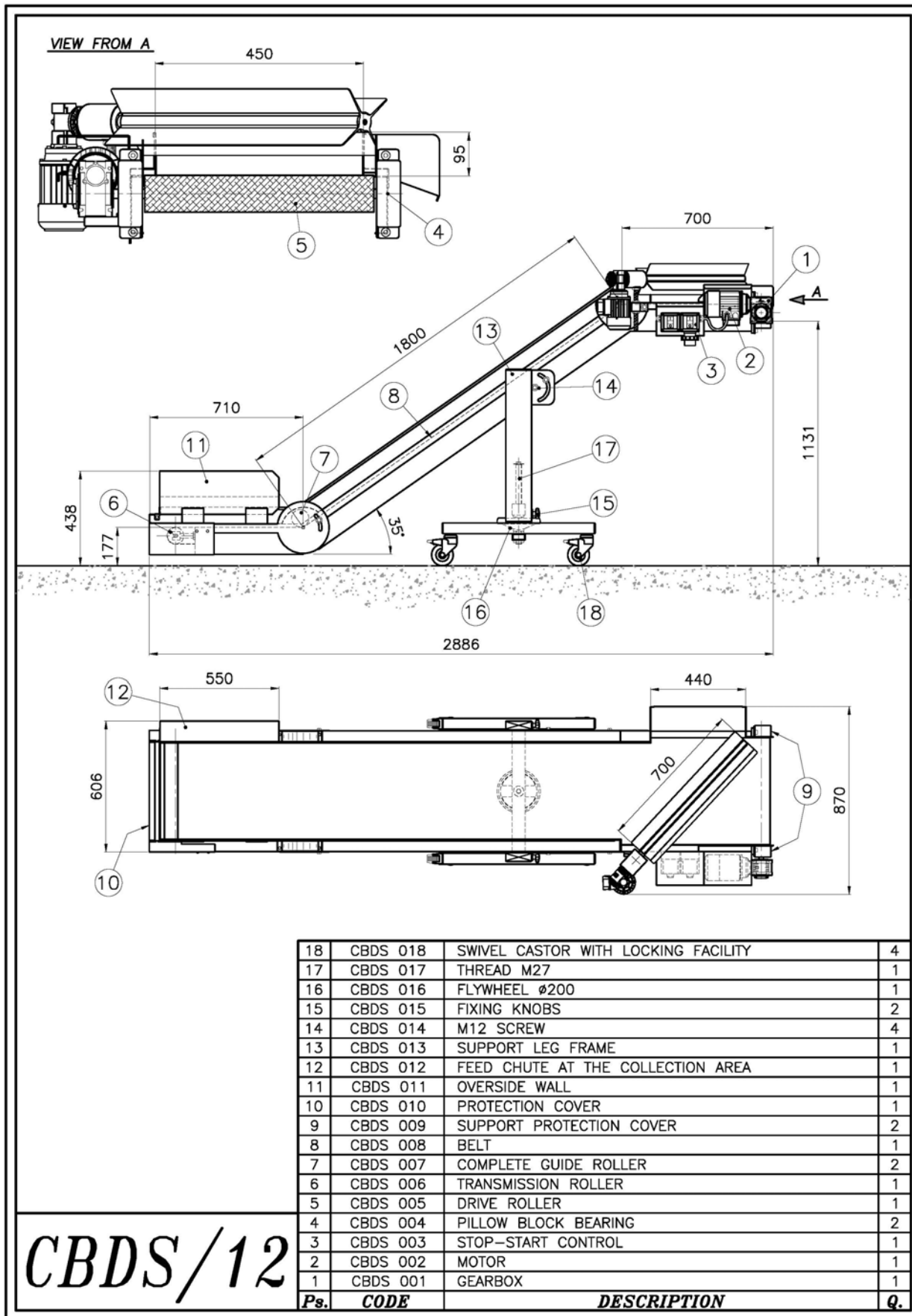

CBDS/12

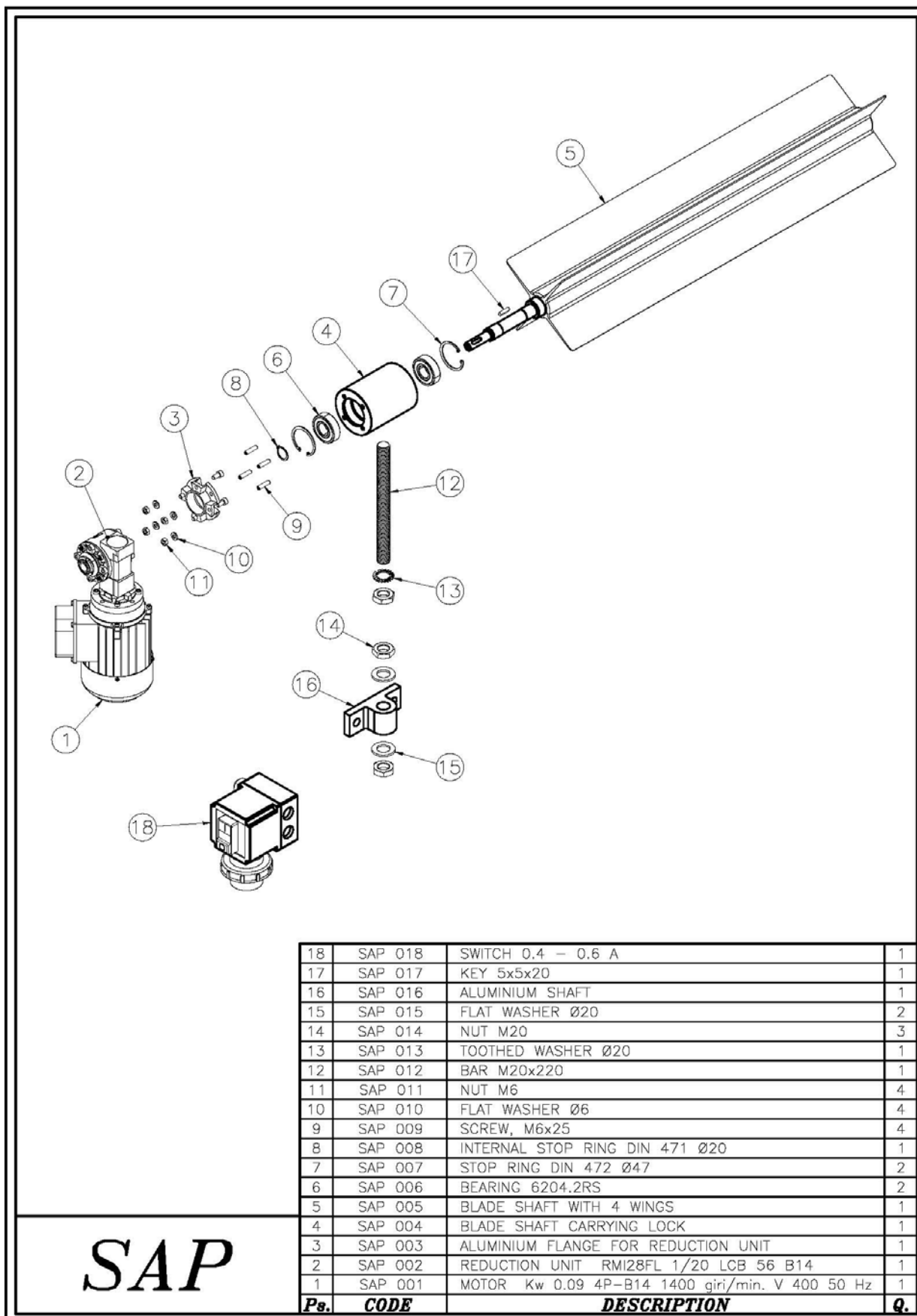

SAP

18	SAP 018	SWITCH 0,4 - 0,6 A	1
17	SAP 017	KEY 5x5x20	1
16	SAP 016	ALUMINIUM SHAFT	1
15	SAP 015	FLAT WASHER Ø20	2
14	SAP 014	NUT M20	3
13	SAP 013	TOOTHED WASHER Ø20	1
12	SAP 012	BAR M20x220	1
11	SAP 011	NUT M6	4
10	SAP 010	FLAT WASHER Ø6	4
9	SAP 009	SCREW, M6x25	4
8	SAP 008	INTERNAL STOP RING DIN 471 Ø20	1
7	SAP 007	STOP RING DIN 472 Ø47	2
6	SAP 006	BEARING 6204.2RS	2
5	SAP 005	BLADE SHAFT WITH 4 WINGS	1
4	SAP 004	BLADE SHAFT CARRYING LOCK	1
3	SAP 003	ALUMINIUM FLANGE FOR REDUCTION UNIT	1
2	SAP 002	REDUCTION UNIT RMI28FL 1/20 LCB 56 B14	1
1	SAP 001	MOTOR Kw 0.09 4P-B14 1400 giri/min. V 400 50 Hz	1
Ps.	CODE	DESCRIPTION	Q.

B.2 COMMANDS

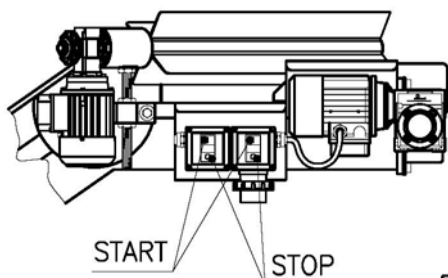

Pic. A

As described in the previous paragraph, the switches with belt start and stop and separator start and stop pushbuttons are positioned near the unloading area (pic. A)

Emergency stop: When necessary, disconnect the belt power plug.

B.3 REGULATIONS

Regulating the belt height (pic. B)

To do this loosen the locking knobs (15), turn the flywheel (16) to regulate, then tighten the knobs (15) again.

Regulating the belt slope (pic. B)

ATTENTION:

If the belt is already sloped, it is thrown out of balance by the lower surface section when the stop nuts are loosened.

Two people are necessary for carrying out this operation, one for supporting and regulating the belt, the other for loosening and tightening the stop nuts (14).

Pic. B

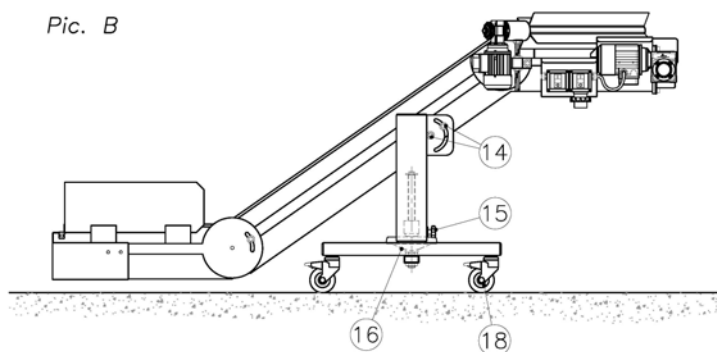

Regulating the height and direction of the blade separator (see diagram on page 9)

To direct the separator along the horizontal plane, loosen one of the two regulation nuts (14). To regulate the height, work on the nuts (14), loosening the lower nut and regulating the height with the upper one.

After regulating, tighten the nuts (14) again to lock in position.

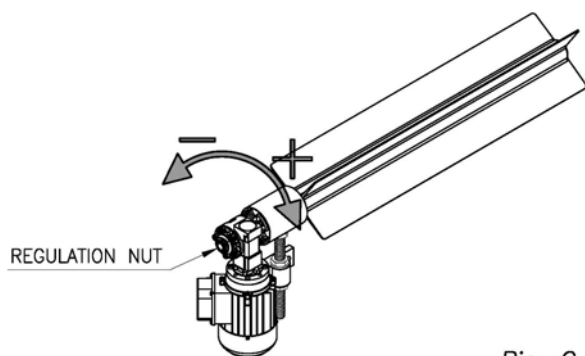

Pic. C

Regulating the separator power (pic. C)

The separator is equipped with a gear which makes it possible to limit the power exerted by the blades, stopping their rotation in case of interference with the transported pieces or the hands of the operator. Tighten the regulation nut to increase the power exercised by the blades or loosen it to decrease the power.

B.4 TRANSPORTATION AND INSTALLATION

Transportation

The belt conveyors are packed using stretch film and the electric panel and reduction unit are also protected by sponge rubber.

ATTENTION

The packaging material (plastic film and sponge rubber) should not be disposed of in the environment but in accordance with current norms.

The belt conveyors should be raised using a fork lift truck. The overall dimensions and mass of the belts in this series are given in para. P1.

DANGER

For operator safety and machine integrity, please refer to pic. C, which shows where to insert the forks in order to raise the belt conveyor in a stable manner.

Once on the lorry loading surface, the machine should be fixed using levers to block the wheels. Suitable slings or fixing methods should also be prepared to ensure stability during transportation.

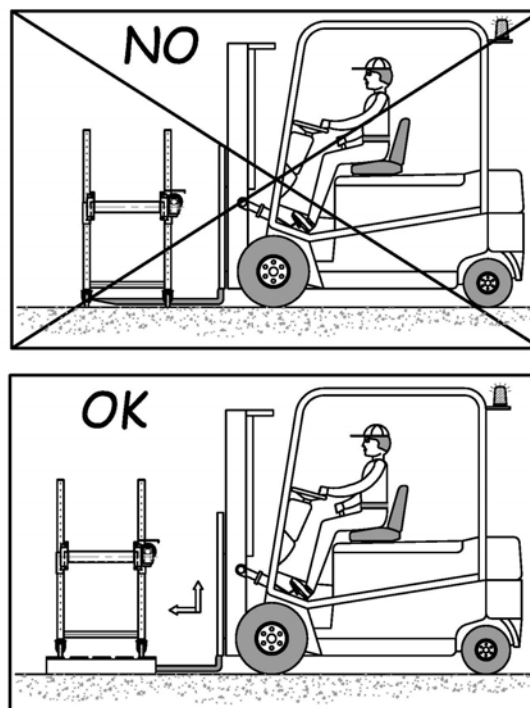

Pic. D

Installation

No particular preliminary operations are necessary when starting the belt conveyors for the first time.

The belt should be connected to an outlet having suitable characteristics. Use the supplied plug.

When laying the cables, please make sure that they are protected against damage and that they cannot trip the operators.

ATTENTION:

Before starting the belt conveyor:

- make sure that the supply voltage corresponds to the one indicated on the plate. The plate can be found next to the belt pushbuttons;
- make sure that the motors are rotating in the correct direction. Make sure that the belt turns in the direction indicated by the arrow on the belt frame.

The belt conveyor should be positioned by inserting the lower surface section (loading area) under the press mould.

ATTENTION:

When the machine has been installed, lock the casters using the levers on each wheel.

SECTION C

Information on maintenance and repairs

C.1 MAINTENANCE INSTRUCTIONS

GENERAL NOTES

The operator must ensure that the machine is kept clean of foreign material such as deposits, oil or others.
The machine should therefore be cleaned at the end of each work shift when it has stopped and is in a stable condition.

ATTENTION:

Before starting, the operator should switch off the belt conveyor and extract the mains plug to avoid any possibility of accidental starting.

If compressed air is used to clean the machine, protective goggles with additional mask should be used. Any people in the surrounding area should also be removed to avoid the danger of being hit and injured by material and dust.

Do not use pressurised water directly on the electric apparatus.

It is forbidden to use flammable liquids for cleaning.

Periodically check the state of the plates and replace them if necessary.

Once the machine has been cleaned, the operator should make sure that there are no worn or damaged parts (if there are, immediately request the intervention of the maintenance technician) or parts that are not solidly fixed (do as much as possible).

The operator and maintenance technician must wear suitable working clothes that do not fly about, and should not wear chains, bracelets or other items that could easily catch in the moving mechanical organs. Operators with long hair should use a hairnet to prevent the risk of entanglement.

The protection and safety devices must not be removed unless a repair and/or maintenance operation is to be carried out.

These devices must be replaced as soon as the reason for their temporary removal has been corrected, and in any case before the machine is started again.

ATTENTION:

At the end of each machine intervention, use the relative levers to lock the wheels.

This series of belt conveyors does not require particular maintenance operations, just some simple interventions.

Inspect to ensure that:

- the reduction units are not leaking lubricant;
- the belt material is tightened correctly (*);
- the belt material is centred correctly (*);
- the electric cable insulation sheath is in good condition (approx. every 2000 working hours).

[*] ATTENZIONE:

Before carrying out this operation, the machine should be put out of service. In addition, the plug should be pulled out from the mains after the belt conveyor has been switched off.

Should it be necessary to regulate the belt, remove the casing at the belt bottom and use the regulation tension rod. To centre the belt material, unscrew the belt bottom casing from both the lower and the upper sections and act on the regulation tension rods. Allow the belt to turn until it is well centred on the cylinder (pic. E).

Pic. E

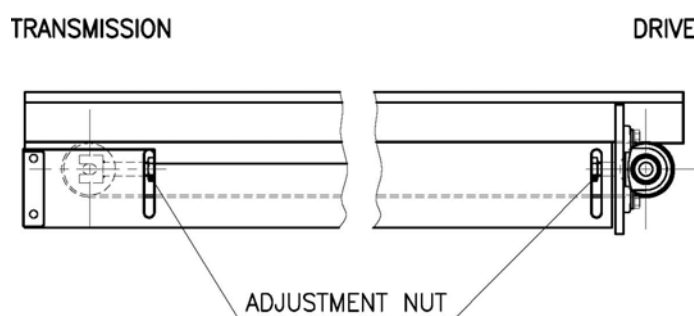

DANGER

To check centring it is necessary to make the belt rotate. Regulate with the machine stopped and make the belt rotate only for the time needed to verify correct belt centring.

Every month make sure that the external temperature of the motor and the reduction unit is not too high (less than 60°C). If faults are found, please contact VIRGINIO NASTRI srl technicians directly.

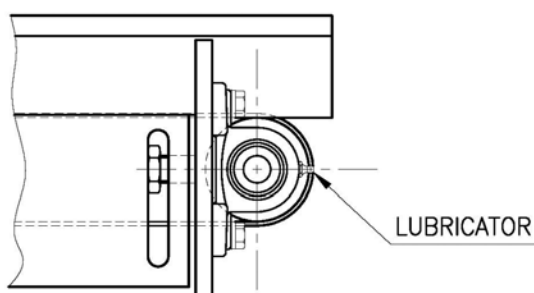

Lubrication:

Every month grease the two supports at the belt discharge point, under the protective casing, as indicated in the drawing (pic. F).

Pic. F

C.2 PLATES AND WARNINGS

The following danger symbol is present on the wrapping of terminal boards that can be powered:



The plate shown below is also present on the belt conveyor:

			
Via Seconda strada,161 -Z.I.			
36071 Arzignano(Vicenza) - ITALY			
Tel. ++39.0444.450620-451520 Fax ++39.0444.671840			
MODELLO MODEL	<input type="text"/>		
MATRICOLA SERIAL NUMBER	<input type="text"/>	ANNO COSTRUZIONE YEAR OF MANUFACTURE	<input type="text"/>

C.3 SPARE PARTS

Whenever it is necessary to order spare parts, please refer to the address given in para. P1. When ordering, always give the part code and the requested quantity of each part ordered.

Note: Only original spare parts supplied by VIRGINIO NASTRI srl guarantee operation reliability.

It should be noted, in particular, that some components have safety characteristics for the personnel, therefore these pieces should only be replaced with the parts recommended by VIRGINIO NASTRI srl.

SPARE PARTS AND CODES

CBDS CODE VIRGINIO NASTRI CONVEYORS

SAP CODE BLADE SEPARATOR

CODE SAP 018

<u>CODE</u>	<u>DESCRIPTION</u>
CBDS 001	
CBDS 002	
CBDS 003	GEARBOX
CBDS 004	MOTOR
CBDS 005	STOP-START CONTROL 0.6 - 1 A
CBDS 006	PILLOW BLOCK BEARING
CBDS 007	DRIVE ROLLER
CBDS 008	TRANSMISSION ROLLER
CBDS 009	COMPLETE GUIDE ROLLER
CBDS 010	BELT
CBDS 011	SUPPORT PROTECTION COVER
CBDS 012	PROTECTION COVER
CBDS 013	OVERSIDE WALL
CBDS 014	FEED CHUTE AT THE COLLECTION AREA
CBDS 015	SUPPORT LEG FRAME
CBDS 016	M12 SCREW
CBDS 017	FIXING KNOBS
CBDS 018	FLYWHEEL Ø 200 mm
SAP 001	THREAD M27
SAP 002	SWIVEL CASTOR WITH LOCKING FACILITY
SAP 003	MOTOR
SAP 004	REDUCTION UNIT
SAP 005	ALUMINIUM FLANGE FOR REDUCTION UNIT
SAP 006	BLADE SHAFT CARRYING LOCK
SAP 007	BLADE SHAFT WITH 4 WINGS
SAP 008	BEARING
SAP 009	STOP RING Ø47
SAP 010	INTERNAL STOP RING Ø20
SAP 011	SCREW, M6x25
SAP 012	FLAT WASHER Ø6
SAP 013	NUT M6
SAP 014	BAR M20x220
SAP 015	TOOTHED WASHER Ø20
SAP 016	NUT M20
SAP 017	FLAT WASHER Ø20



VIRGINIO NASTRI srl

Via Seconda Strada,161 - Z.I. - 36071 ARZIGNANO (VI) ITALY

++39-0444 450 620 - ++39-0444 651 520 - Fax ++39-0444 671 840

E-mail: info@virginionastri.com - Web Site: www.virginionastri.com

ALUMINIUM
SHAFT
KEY 5x5x20
SWITCH 0.4 -
0.6 A

C.4 WIRING DIAGRAM

