

OPERATION MANUAL

ENGLISH

Translated from the original language Italian



HOPPER DRYER

Type: EDB_21_22_23

MUI EDB_21_22_23 Rev 2

OPERATION MANUAL

INDEX

- WARRANTY
- INTRODUCTION
- DECLARATION OF "CE" CONFORMITY
- GLOSSARY
- SYMBOLS
- SYMBOLS
- PROTECTION AND SAFETY DEVICES
- TRANSPORT AND HANDLING
- INSTALLATION AND CONNECTIONS
 - LIGHTING
 - VIBRATIONS
 - NOISE LEVELS
 - RESIDUES AND ENVIRONMENTAL POLLUTION
 - INSTALLATION PLACE
 - TEMPERATURE LEVELS
 - SAFETY REGULATIONS FOR INSTALLATION
 - ELECTRICAL CONNECTIONS
 - MECHANICAL CONNECTIONS
 - PNEUMATIC CONNECTION
- MACHINERY DISINSTALLATION AND DISPOSAL
- MACHINERY DESCRIPTION
- GETTING STARTED
- SETUP
- WORKING CYCLE
- ALARM TYPES
- MAINTENANCE
- TROUBLESHOOTING
- TABLES:
 - 1 IDENTIFICATION LABEL
 - 2 CONTROL PANEL
 - 3 TECHNICAL DATA
 - 4 SPARE PARTS
 - 5 OPERATING DIAGRAM
 - 6 INSTALLATION EXAMPLES
 - 7 ELECTRICAL DIAGRAMS

EDB_21_22_23

WARRANTY

The Selling Company gives warranty to the Purchaser for its machineries manufactured, object of the Deed of Sale. The warranty is not extended to the Purchaser's assignees. The Purchaser has a period of one-year-warranty from the date of the invoice.

Warranty consists in repairing or replacing services free of charge of useless parts, whose faults derive from the Seller's responsibility, such as:

- Defects or faults in the material and their assembling or manufacturing process;
- Terms of Use described in the Operation Manual;
- Proper usage of the machinery.

The Selling Company is not responsible:

- For faults due to causes arising after delivery;
- For damages caused by third persons;
- For defects arising from materials or projects supplied by the Purchaser;
- For faults or breaks due to fatigue, careless maintenance, incompetence, negligence or an improper use of the machinery by the Purchaser;
- For usage not foreseen by the Operation Manual;
- For a wrong usage of the machinery by the Purchaser;
- For modifications or repair operations of the machinery, or of parts of it, are carried out without permission by the Selling Company.

Warranty of electrical and electronic components supplied with the machinery expires after its first running.

If the Purchaser does not respect the expiry dates for payments, the warranty will be not considered valid any longer.

Repairing and replacing operations:

- If they take place at the Sellers' factory, costs for transporting the goods will be on charge of the Purchaser.
- If they take place on the installation place and are due to reasons not depending on the Seller, operator's and technician's expenses for travelling and accommodation will be on charge of the Purchaser, according to the rates published by ASSOCOMAPLAST for this purpose (visit www.assocomoplast for further information).

The Selling Company has no other obligations except the repairing and replacing duties mentioned above, and in particular the Buyer will not have the rights of the Contract of Purchase or any other damage claim.

In any case, each Arbitration about faults, defects, lack of quality, performance or requirements, for any other reasons or claims, without affecting the law (art.1495 Italian Civil Code), shall be proposed by the Purchaser within 12 months from date of invoice to be valid. It can not be proposed when the Purchaser is in arrears, even for a single instalment. Any dispute shall be submitted to the court of justice in Padua (Italy).

OPERATION MANUAL

INTRODUCTION

This Operation Manual aims:

- To be the correct guide for installation, use, maintenance and disinstallation of the machinery concerned. IRV Systems will not be responsible for damages connected with installation, use, maintenance and disinstallation when they are not done following the instructions given in this Operation Manual. In particular, the company will not be responsible for an improper use of the Operation Manual.
- To safeguard the user's safety preventing from improper actions and/or operations. IRV Systems will not be responsible for to injuries to people or damages to things due to incompetence and/or when the safety instructions contained in the Operation Manual will not be followed. In particular, the company will not be responsible for an improper use of the Operation Manual.
- To be an integral part of the machinery for its whole life cycle. Each machinery sold by IRV Systems comes along with an Operation Manual that contains instructions about installation, use, maintenance and disinstallation of the machinery itself. The content of the Operation Manual is valid for the whole life cycle of the machinery: the Purchaser must keep the Operation Manual from the moment of installation till the moment of disinstallation of the machinery. The content of the Operation Manual is valid for the whole life cycle of the machinery: the Purchaser must keep the Operation Manual from the moment of installation till the moment of disinstallation of the machinery. Moreover, the Operation Manual must be given to any other possible purchaser or owner of the machinery.

Important Notes:

- in case of doubts or uncertainty about the interpretation of words, passages, sections, schemes and/or pictures contained in the Operation Manual IRV Systems places its Technical Support at your own disposal for any further explanation.
- In this way IRV Systems declines any responsibility deriving from an improper use of the Operation Manual.
- Some of the pictures included in the Operation Manual, meant to detect the parts described easily, can be not the same as the corresponding parts of the machinery purchased: this is due to the need of generalisation.
- Finally, IRV Systems reserves the right to make the necessary modifications without notice in order to improve its machineries.

EDB_21_22_23**DECLARATION OF "CE" CONFORMITY**

THE MANUFACTURER:

IRV Systems Srl
Via R.Colpi, 38
35010 Limena (PD)
Italy



STATES THAT:

The product: DEHUMIDIFYING UNIT

Type: EDB 21-22-23

Serial number: _____

Is in compliance with the directives:

- 2006/42/EC of the European Parliament and of the Council of 17th May 2006 on machinery and amending directive 95/16/EC,
- 2004/108/EC of the European Parliament and of the Council of 15th December 2004 on the approximation of the laws of the Member States relating to electromagnetic compatibility and repealing Directive 89/336/EEC,
- 2006/95/EC of the European Parliament and of the Council of 12th December 2006 the approximation of the laws of the Member States relating to electrical equipment designed for use within certain voltage limits,

Is in compliance with the harmonized Regulations:

- UNI EN ISO 12100-1,
- UNI EN ISO 12100-2,
- CEI EN 60204-1,
- UNI EN 1050,
- UNI 75454,
- CEI EN 60529/A1
- UNI EN ISO 13849-1

A person authorized to keep the relevant technical documentation is:
Mr. Schiavolin Christian, Via R. Colpi, 38 – 35010 Limena (PD) – Italy

Limena (PD), il 01/07/2011
Christian Schiavolin, Managing Director (Signature)

A handwritten signature in black ink, appearing to read 'Christian Schiavolin', is written over a horizontal line.









OPERATION MANUAL

GLOSSARY

Skilled Operator:	Person(s) appointed to install, operate, regulate, maintain, clean, repair, or transport the machinery. This kind of operator has technical knowledge or is experienced enough in order to avoid dangers connected with the operations to be done, also when parts are under tension.
PSA	Bulk Specific Gravity (<i>Peso Specifico Apparente</i>): the weight of a litre of granular plastic material. the weight of a litre of granular plastic material.
UNI	Italian National Board for Unification (<i>Ente Nazionale Italiano di Unificazione</i>).

SYMBOLS

The column on the left in the following table contains symbols which refer to a specific dangerous situation. Their respective meaning is described in the column on the right.

Symbol	Description
	Do not remove safety equipment
	Danger: High Temperature
	Generic Danger Sign
	Danger of Death
	High Voltage Danger
	Mandatory warning sign: safety shoes must be used.
	Mandatory warning sign: safety gloves must be used.
	Mandatory warning sign: safety glasses/visors must be used.
	Respect the environment.

Symbols do not substitute danger warnings written in the column on the right; they are meant to emphasize them.

Symbols are taken from Directive 77/576/CEE.

EDB_21_22_23

PROTECTION AND SAFETY DEVICES

GENERIC CONSIDERATIONS: MACHINERIES HAVE BEEN ENGINEERED SO THAT OPERATING, SETTING AND MAINTAINING THEM DOES NOT REPRESENT ANY RISK FOR PEOPLE, IF SUCH OPERATIONS WILL BE CARRIED OUT FOLLOWING THE INDICATIONS GIVEN.

CONTROL DEVICES: CONTROL DEVICES HAVE BEEN ENGINEERED SO THAT THEY ARE SAFE AND RELIABLE. EVERY DANGEROUS SITUATION IS AVOIDED. IN CASE OF LOGISTICS MISTAKES WHEN OPERATING THE MACHINERY, DANGEROUS SITUATIONS CAN NOT OCCUR.

STARTING: A MACHINERY CAN BE STARTED BY A VOLUNTARY ACTION THROUGH THE SWITCH PROVIDED ONLY. THE SAME IS TRUE WHEN THE MACHINERY WILL BE STARTED AGAIN AFTER IT HAS BEEN STOPPED.

RISKS OF MACHINERY BREAKDOWN DURING THE WORKING PROCESS: BOTH THE COMPONENTS OF OUR MACHINERIES AND CONNECTIONS DEVICES HAVE BEEN ENGINEERED TO RESIST THE FATIGUE THEY MUST UNDERGO DURING THE WORKING PROCESS. . DIRECT RISKS FOR PEOPLE OR THINGS CAN NOT OCCUR IN CASE THE MACHINERY OR PARTS OF IT BREAK DOWN

WARNING: ALL OPERATORS USING THE DEVICE MUST READ THE OPERATION MANUAL CAREFULLY. IN PARTICULAR THEY MUST BE ACQUAINTED WITH ITS DANGEROUS PARTS, ITS CONTROL BUTTONS, THE COMMON SAFETY REGULATIONS IN ORDER TO PROTECT ALL OPERATORS FROM ACCIDENTS AND THE MACHINERY FROM DAMAGES THAT MAY OCCUR.

WARNING: POSSIBLE UNAUTHORIZED MODIFICATIONS TO THE DEVICE MAY CAUSE SUDDEN DANGERS AND OUR COMPANY WILL NOT BE RESPONSIBLE FOR THEM; IT SHALL ASSUME NO LIABILITY AS REGARDS CIVIL AND PENAL RESPONSIBILITY.

WARNING: WEAR CLOTHING IN CONFORMITY WITH SAFETY REGULATIONS 89/656/CE AND 89/868/CE ABOUT PERSONAL PROTECTION WHEN OPERATING NEARBY THE MACHINERY.

WARNING: THE AREA WHERE THE DEVICE HAS BEEN INSTALLED MUST ALWAYS BE FREE OF HINDRANCES, SO THAT OPERATORS CAN HANDLE QUICKLY IN CASE OF GENERIC ALARMS.

WARNING: THE DEVICE HAS BEEN ENGINEERED IN ORDER TO BE OPERATED WITH THERMOPLASTIC MATERIALS AND WITH QUANTITIES GIVEN. ANY USE OF THE MACHINERY THAT SOULD NOT BE IN COMPLIANCE WITH THE RULES AND REGULATIONS MENTIONED ABOVE HAS TO BE CONSIDERED NOT PROPER AND OUR COMPANY DOES NOT ASSUME LIABILITY AS REGARDS CIVIL AND PENAL RESPONSIBILITY

WARNING: IT IS EXPRESSELY FORBIDDEN TO REMOVE OR TO MODIFY ANY MECHANICAL OR ELECTRICAL SAFETY ON THE DEVICE; THE COMPANY WILL ASSUME NO LIABILITY IN CASE OF OPERATIONS NOT ALLOWED IN THIS MANUAL.



WARNING: IT IS NECESSARY TO FOLLOW THE ORDINARY MAINTENANCE PROGRAMM EXPLAINED TO LET THE DEVICE WORK PROPERLY.

OPERATION MANUAL

WARNING: THE ELECTRICAL SYSTEM TO WHICH THE DEVICE WILL BE CONNECTED MUST BE IN COMPLIANCE WITH THE REGULATIONS IN FORCE AND MUST BE CHECKED BY QUALIFIED TECHNICIANS PERIODICALLY.



WARNING: IT IS NECESSARY TO SWITCH OFF THE ELECTRIC POWER USING THE LINE ARRESTER ON THE FRONT SWITCHBOARD BEFORE CARRYING OUT OPERATIONS ON ANY PART OF THE DEVICE THAT DO NOT CONCERN THE NORMAL WORKING PROCESS.

WARNING: IT IS NECESSARY TO CHECK IF THE GROUNDING SYSTEM WORKS PROPERLY BEFORE CONNECTING THE DEVICE TO THE POWER LINE.

WARNING: IT IS NECESSARY TO SWITCH OFF THE ELECTRIC POWER OF THE DEVICE IN CASE OF FAULTS OR DAMAGES OF ITS CONTROL SYSTEM AND TO CONTACT OUR TECHNICAL SUPPORT; POSSIBLE UNAUTHORIZED MODIFICATIONS MAY NOT BE CORRECT AND THE DEVICE MAY NOT WORK PROPERLY; IN THIS CASE OUR COMPANY WILL ASSUME NO LIABILITY.

UNPACKING OPERATIONS



During unpacking operations workers must wear safety gloves in order to avoid possible injuries due to contacts with steel strips, splinters or any other element that can cause cuts or grazes.

TRANSPORT AND HANDLING

RIGHT POSITION WHEN LIFTING BY MEANS OF A PALLET TRUCK.

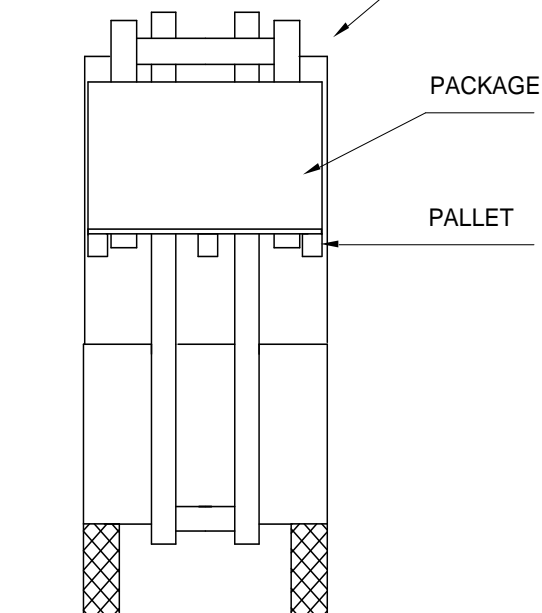

EDB_21_22_23

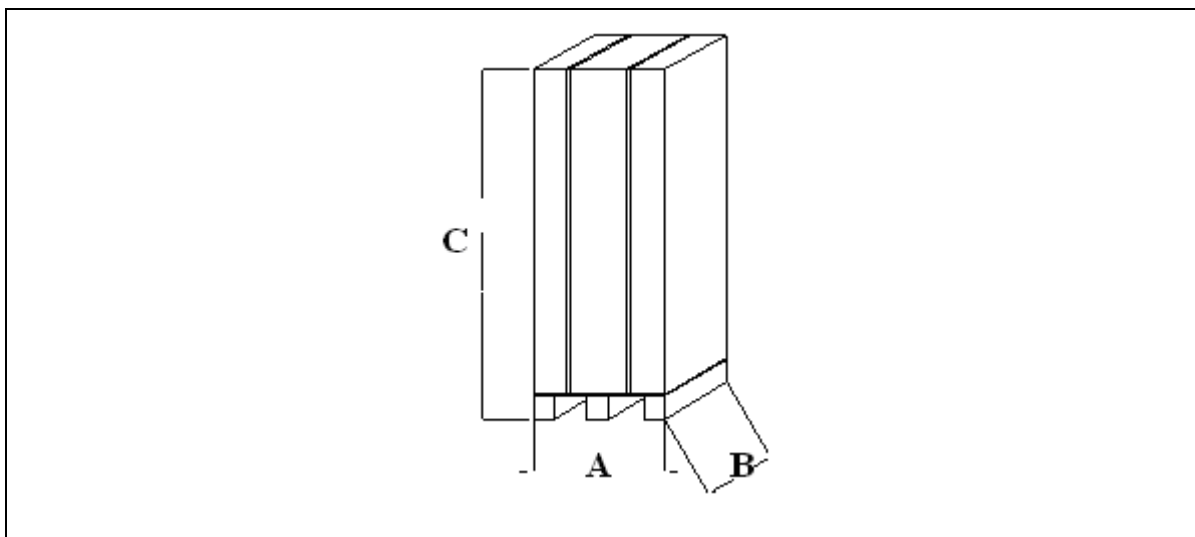

TYPE	DIMENSIONS		
	A	B	C
EDB			
EDB21 HB15	700 mm	660 mm	1100 mm
EDB21 HB30	500 mm	560 mm	1100 mm
EDB21 HB60	700 mm	660 mm	1100 mm
EDB22 HB60	700 mm	660 mm	1100 mm
EDB22 HB100	760 mm	700 mm	1420 mm
EDB22 HB150	760 mm	760 mm	1550 mm
EDB23 HB150	760 mm	760 mm	1550 mm
EDB23 HB200	760 mm	760 mm	2100 mm
EDB23 HB300	1000 mm	1000 mm	2200 mm



During transport our machineries are usually protected by a layer of plastic material with air bubbles, with cardboards, or by proper pallets with cardboards forming a package like a packing case.

The package must be lifted by means of a pallet truck.

Transport and lifting are always dangerous operations: be careful and follow safety measures when lifting the load.

Use proper means of transport that can protect the package and the machinery integrity when transporting the machineries for a long distance.

INSTALLATION AND CONNECTIONS

  	<p>Installation operations must be carried out in safe conditions for the workers involved and for other people who may be nearby at the moment.</p> <p>To limit the occurrence of risks and accidents, operators must be equipped personally with all necessary safety means, according to the kind of activity involved (for example: safety gloves, safety glasses, safety shoes, etc.). Moreover, working areas must be marked out by means of signal bands; proper danger warning signs must be placed in all strategic areas concerned during installation operations.</p>
---	--

OPERATION MANUAL

LIGHTING When operating the device in normal conditions, it is necessary that lighting in the room where the machinery has been installed can allow the immediate localization of safety devices and in particular of the control panel. If supplementary maintenance operations have to be carried out, a stronger light is necessary so that maintenance operations can be carried out without danger. Handle in compliance with the Regulations in force as regards lighting quantity and intensity both in the room and on the device.

VIBRATIONS Even when the device operates at high working schedule, vibrations do not cause dangers to users nor do they to the surrounding equipments. If anomalous vibrations are noticed, the first thing the user must do is to switch off the mains through the line arrester in front of the control panel.

NOISE LEVELS As regards noise levels, the machinery has been engineered to reduce noise pollution. As one can see in the table of technical data, noise pressure in db nearby the device is not high and, moreover, the users spend most of the time of their daily work not necessarily near the machinery.

RESIDUES AND ENVIRONMENTAL POLLUTION Materials usually handled with this kind of machineries are in compliance with prEN626-1 and are not considered harmful. Moreover, our machineries are provided with a filter for the treatment of the material with an open circuit, so the room in which the device is placed must be dimensioned and ventilated properly so that the limit of 3 g/m³ of concentration of thin dusts in the air will be never exceeded; beyond this limit there could be serious consequences for operators health.

INSTALLATION PLACE In order to get the device full functionality, following requirements must be fulfilled before installing the machinery:

- Unload the machinery by means of a pallet truck. Remove the package by opening the cardboard and removing the layer: be careful in this phase that operators do not get hurt. Place the device so that there is at least 1,0 m. distance on every side around its perimeter and from the machinery to the roof. On the front side, where the control panel can be found, the distance from possible hindrances must be at least 2,5 m.
- The room where the device will be placed shall be protected by the action of atmospheric agents such as rain, hail, snow, and so on.
- The environment must be free from corrosive substances that can cause damages to the electrical equipment and thus to the whole safety system.
- Installation can not be carried out in environments where explosives are at hand.
- Installation must not be carried out near devices that can issue electromagnetic radiations.

TEMPERATURE LEVELS

The machinery working cycle has a constant hot air flow that involves both the device and the transport pipes; the air temperature can reach temperatures even of 150°C. Remember that pipes carrying hot air towards and from the hopper can reach temperatures of 150°C, and so it is advisable to install and protect to them in a place that is not reachable by operators (TABLES 2, 6, 7).



WARNING: Parts of the machinery could have high temperature levels during the working process.

EDB_21_22_23

SAFETY REGULATIONS FOR INSTALLATION Handle in compliance with following Regulations to install the machinery without dangers for the operators concerned.

The device must be placed in a room with proper lighting in compliance with Regulation CEI EN 60204-1. The device must be placed in a room with grounding system in compliance with Regulation CEI 64-8. The device must be placed in a room with electrical wiring in compliance with the Regulations in force

ELECTRICAL CONNECTIONS

The connection of the device to the electrical power supply must be carried out by a specialized technician (electrician) in compliance with the regulation CEI 64-8. Do following before connecting the machinery:

- Check the power socket potential (three-phase socket – neutral – grounding) that must be of following Ampere: see Table Technical Data.
- Check if the tension and frequency of the power transmission system correspond to that on the machinery identification label;
- Check the grounding efficiency;
- Check the tension variation that must be within the value of $\pm 10\%$;
- Check the frequency variation that must be within the value of $\pm 2\%$;
- Use a power cable (a single-phase or a three-phase cable) with section in compliance with the Regulations in force;
- The cables connections on the terminal board must be in compliance with the Regulations in force;
- It is important to protect the device from overvoltage and overload current of the power line by using automatic switches
- The connection between the machinery and the power panel shall be done using the cable coming out from the machinery itself to an alternating current distribution point (provided with grounding connection)

If the provided cable shall be replaced, the new one must have the same characteristics of the old one. If the cable length is longer, the cable diameter must be estimated according to its length and power of the machinery.

See **ELECTRICAL DIAGRAMS**

OPERATION MANUAL

MECHANICAL CONNECTIONS:

The mechanical connections are not foreseen, but it is meant the positioning nearby the hopper to be supplied (the pipe length should be max 2 m.); for different uses please contact our Technical Support.

See **INSTALLATION EXAMPLES**

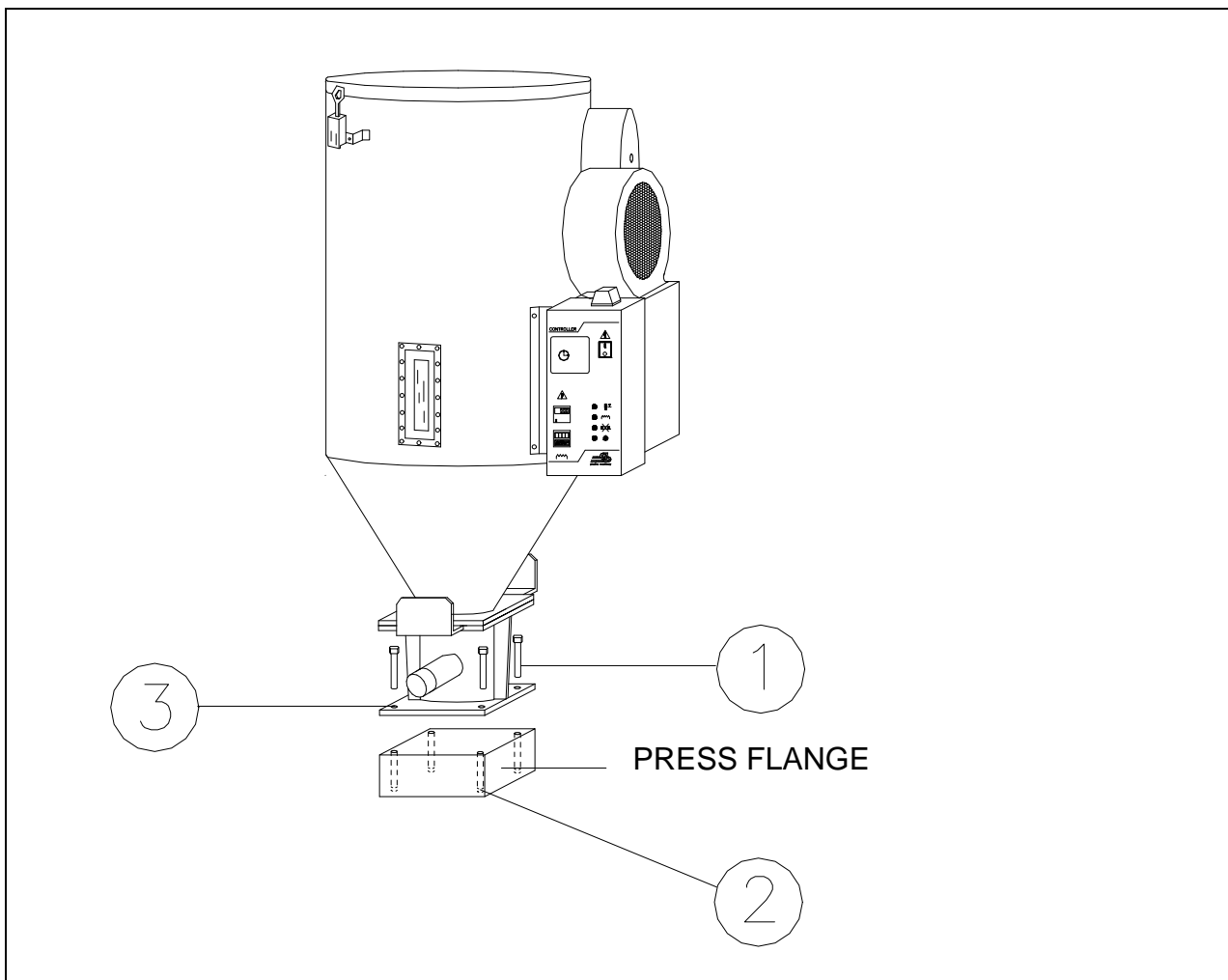

ASSEMBLING DATA

N°	EDB21 HB15	EDB21 HB30	EDB22 HB60	EDB22 HB100	EDB22 HB150	EDB23 HB150	EDB23 HB200	EDB23 HB300	DESCRIPTION
1	M8	M8	M10	M10	M12	M12	M12	/	SCREWS UNI 5739 ACC 8.8
2	20mm	20mm	30mm	30mm	30mm	30mm	30mm	/	THREAD DEPTH

PNEUMATIC CONNECTIONS:

Not foreseen

EDB_21_22_23

MACHINERY DISINSTALLATION AND DISPOSAL

Follow the indications described in the previous section 'INSTALLATION AND CONNECTIONS' carefully to carry out all disinstallation and disposal operations of the machinery. Disconnect the power supply and dispose the machinery.

Be careful not to scatter solids, fluids or gases into the environment in order to avoid damages to people and to things; convey them into proper containers and dispose them according to the Regulations in force in your country.

MACHINERY DESCRIPTION

The device is prepared for thermic treatment of plastics in granular form. It generates hot-air, which serves to accelerate the plasticization process of the press or the extruder. The heating process can foster the discharge of water from plastics in proportion to the outer environmental conditions. The device consists of a fan, a resistance, a switchboard with thermoregulator and a filter for input air. The device shall be used together with a container or hopper that can contain the material to be treated.

See **OPERATING DIAGRAM**

GETTING STARTED

To start the machinery :

- Set the main switch on the machinery switchboard on "ON"-position.
- Set the alarm temperature (at least 20° C higher then the alarm temperature) on the process thermoregulator (or on the alarm thermoregulator if available).
- Set the working temperature on the thermoregulator (GIVEN BY THE MANUFACTURER OF THE PLASTIC MATERIAL TO BE TREATED)

SETUP (Thermoregulator)

The thermoregulator is a device that measures and displays the temperature at a certain working point and allows to set its – i.e. by means of some resistances.

Characteristics of the TLK39 thermoregulator:

- The upper part of the display shows the temperature measured by the drill in red;
- Depending on the default settings, the lower part of the display visualizes the operating or the alarm temperature in green

Both temperature values can be set by the user.



Fig.1

Follow the instructions given below to display and modify operating and alarm temperatures:

- press button P: 'SP1' or 'AL1' will be shown on the upper row, depending on the temperature you are going to set, and on the lower row the temperature value set will be shown (see fig. 2 or 3).
- Regulate the temperature using the arrow buttons '▲▼'.
- Press the P button to save and exit.

OPERATION MANUAL

NOTICE: The settings of the thermoregulator are always set with standard data by SB Plastics Machinery; it is strongly recommended not to modify the temperature values so that the right working conditions and the warranty will not be affected. The temperatures set are different depending on the use of the thermoregulator: it is recommended to set the alarm temperature (AL1) 20°C higher than the working temperature (SP1).

Ex.: 50°C (SP1) + 20°C = 70°C (AL1)



Fig.2



Fig.3

Indicative diagram

MATERIAL	DRYING TEMPERATURE	MIN. PROCESSING TIME	DRYER CAPACITY + HOPPER [Kg/h]								
			EDB21	EDB21	EDB22	EDB22	EDB22	EDB23	EDB23	EDB23	EDB23
	°C	h	HB15	HB30	HB60	HB60	HB100	HB150	HB150	HB200	HB300
PC	120	1.5	5	10	22	23	43	60	70	95	120
ABS	80	2	3	7	15	19	30	40	45	58	78
PVC	70	1	9	18	33	39	62	78	85	130	160
PMMA	80	2	4	8	17	20	32	42	50	69	88
PS	80	1	6	12	33	39	55	82	92	122	155
PE	80	1	6	12	33	39	52	72	80	110	140
PP	90	1	5	10	28	37	50	70	78	103	132

EDB_21_22_23

WORKING CYCLE

When the machinery will be started, it will begin to insulate air within the hopper and, at the same time, it will heat that air till it will reach the temperature set on the thermoregulator.

This condition will be active till the machinery will be stopped by means of the main switch.

It is different if the machinery is equipped with a clock (optional device), which will operate the blower according its own program when the machinery is on.

ALARM TYPES

OVERTEMPERATURE ALARM

When air temperature is higher than the alarm temperature set on the process thermoregulator

When air temperature is higher than the alarm temperature set on the safety thermostat (within the electrical box)

When air temperature is higher than alarm temperature set on the safety thermoregulator(if installed).

MOTOR THERMOSWITCH ALARM

- When the motor gets broken during the work cycle
- When the motor impeller is obstructed
- When a phase is not connected
- When there is a wrong connection between phase and neutral.

All warning signs will turn off automatically as soon as the anomaly(ies) are removed and machinery normal working conditions are restored.

MAINTENANCE

Maintenance operations must be carried out by qualified technicians.

Maintenance and inspection operations carried out carefully and at regular intervals are necessary to remove failures before they can cause worse damages.



All maintenance operations, except when it is expressly required, must be carried out only when the device is not supplied with electric power totally, that is, only after having turned off the main switch of the feeder and that between the mains and the device itself.

FILTER CLEANING

The equipped filter is fit to stop all raw polluting elements that by chance may be aspirated together with air, like leaves, paper sheets, rags, pieces of plastic films, etc.. However, it is not excluded that the filter may get obstructed in dusty environments.

It is recommended to carry out cleaning operations periodically: clean the filter, the cone diffuser and its filter within the hopper. Pull it out from its seat after having tilted the hopper cover and clean it by means of high-pressure air (6-8bar).

HOPPER CLEANING

It is recommended to clean the hopper carefully each time you use different material(s). To make this operation easier, the hopper has been engineered and realised so that after you open the cove, you can draw out the inner cone diffuser very easily, as seen before. After that you only need to clean it by means of high-pressure air (6-8bar).

OPERATION MANUAL

MACHINERY EFFICIENCY

Machinery efficiency will get lower when one or more of following conditions occur:

1	FILTER AND/OR PIPES OBSTRUCTED
2	TOO LOW HOPPER AIR TEMPERATURE
3	THE FAN DOES NOT RUN
4	REDUCTION OF AIR CIRCULATION
5	THE LED FOR OVERTEMPERATURE TURNS ON

TROUBLESHOOTING

TOO LOW HOPPER AIR TEMPERATURE	
CAUSE	SOLUTION
FAULTY FUSE F1	REPLACE THE FUSE
FAULTY CONTACTOR (K1-K2)	REPLACE THE CONTACTOR (K1-K2)
FAULTY THERMOREGULATOR (T1 - T2)	REPLACE THE THERMOREGULATOR (T1 - T2)
HEATING COMPONENT (R)	REPLACE THE HEATING COMPONENT (R)
FAULTY THERMOREGULATOR DRILL (T1 - T2)	REPLACE THE DRILL (T1 - T2)
THE FAN DOES NOT RUN	
CAUSE	SOLUTION
FAULTY FAN MOTOR	REPLACE THE FAN
LINE CABLE NOT CONNECTED	CONNECT THE LINE CABLE
NO POWER SUPPLY	CONNECT THE POWER SUPPLY
FAULTY SWITCH(IG)	REPLACE THE SWITCH
MOTOR THERMOSWITCH DEACTIVATED	REACTIVATE AND CHECK (PHASES) PRESENCE
AIR CIRCULATION AND EDB EFFICIENCY REDUCED	
CAUSE	SOLUTION
PAPER FILTER	CLEAN OR REPLACE THE FILTER
CONE DIFFUSER FILTER	CLEAN OR REPLACE THE FILTER
METALLIC FILTER	CLEAN OR REPLACE THE FILTER
FAN STOPPED	CHECK (FAN DOES NOT RUN)
TEMPERATURE TOO LOW	CHECK (TEMPERATURE TOO LOW)
OVERTEMPERATURE LED TURNS ON BOTH ON THE PANEL (B) AND THE UPPER ONE	
CAUSE	SOLUTION
CHECK T2-VALUE; IT MUST BE 10°C HIGHER THAN T1-VALUE	RESET VALUE (T2)
FAULTY THERMOREGULATOR (T2)	REPLACE THERMOREGULATOR (T2)
FAULTY THERMOREGULATOR DRILL (T2)	REPLACE THE DRILL (T2)
NEITHER LEDS NOR THERMOREGULATORS TURN ON	
CAUSE	SOLUTION
FAULTY FUSE F2	REPLACE THE FUSE

EDB_21_22_23

TABLE 1 - IDENTIFICATION LABEL

		Serial Number		M/A - M/Y	
Codice / Code		Descrizione / Description			
Kw	Volt	Hz	A	Phase	Kg.
IRV SYSTEMS SRL - Via G. Marconi, 42 - Villanova di Camposampiero (PD) ITALY - Tel. +39 049 88 43 047 - Fax +39 049 88 43 604					

TABLE 2 - CONTROL PANEL

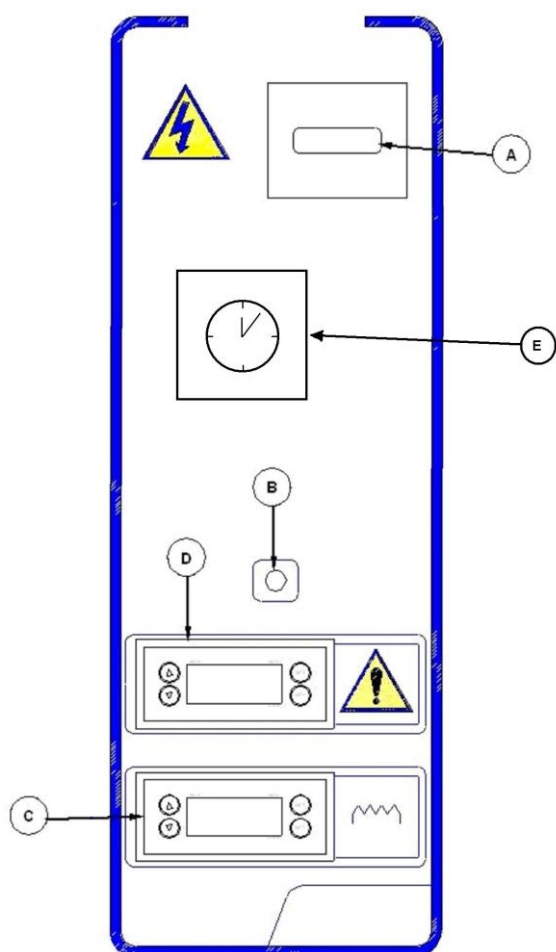

A – MAIN SWITCH It switches the machinery power supply on or off

It can be of two different colours:

- GREEN: when the machinery works properly
- RED: when there is an alarm which can be due to over temperature or to the interruption operated by the fan magnetothermic switch.

B – LED

C – PROCESS THERMO-REGULATOR

It allows to set drying process and safety temperature if D is not installed.

D – SAFETY THERMO-REGULATOR (OPTIONAL)

It allows to select the safety temperature value. Every time it will be exceeded, the led will turn on and the resistance will be deactivated so that faults can be avoided.

E – DAILY/WEERKLY PROGRAMMING DEVICE (OPTIONAL)

It allows to program the machinery turning on and off within the week

OPERATION MANUAL

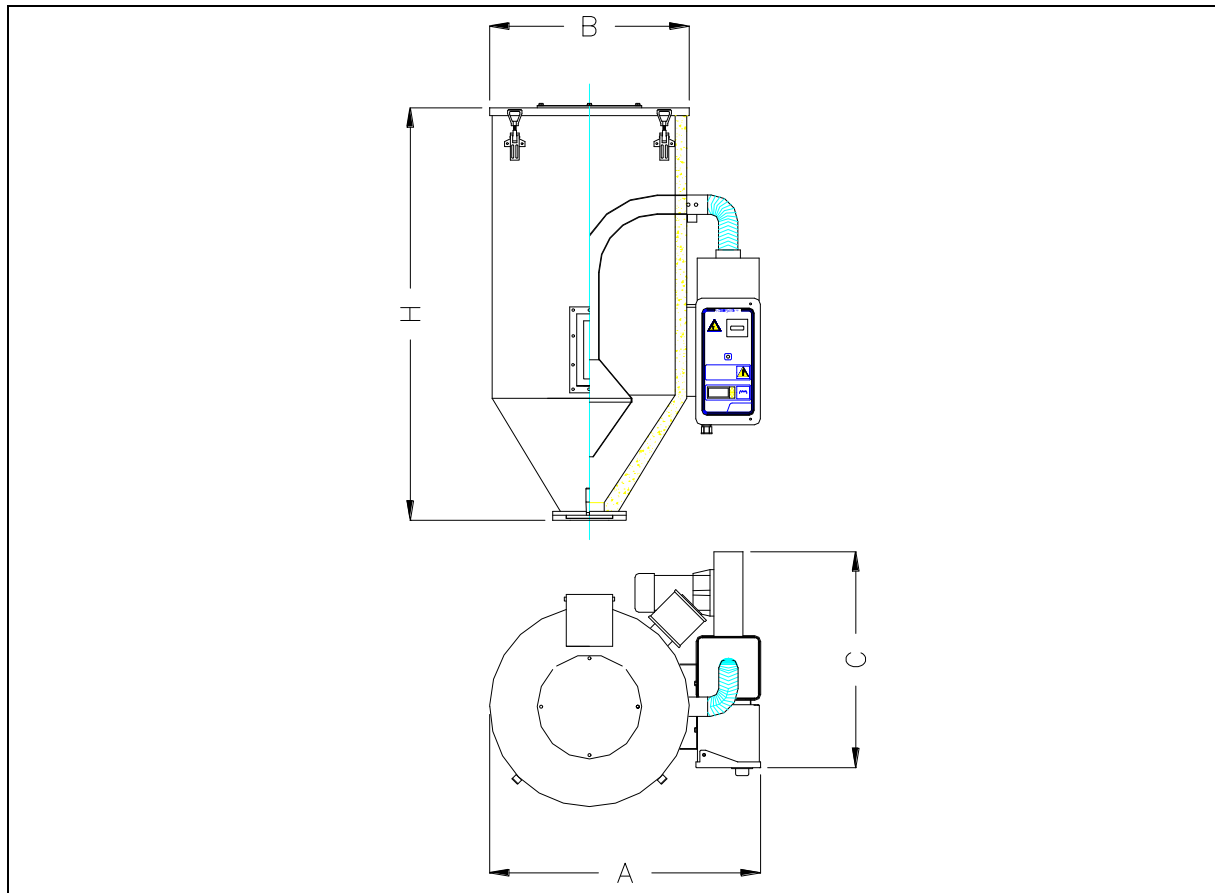
TABLE 3 - TECHNICAL DATA

TECHNICAL DATA				
HOPPER DRYER	EDB21	EDB22	EDB23	
MOTOR TYPE	SINGLE-PHASE 230V – 50Hz			
MOTOR POWER	0.09 kW	0.12 kW	0.18 kW	
HOPPER AIR CAPACITY	30 m ³ /h	75 m ³ /h	125 m ³ /h	
HEATING POWER	1.5 kW	2.7 kW	3.5 kW	
POWER SUPPLY CABLE DIAMETER	2.5 mm ²			
HOPPER CAPACITY	15-30 lt	60-100-150 lt	150-200-300 lt	
DIMENSIONS mm	A	503	613-703-695	695-695-890
	B	353	413-503-495	495-495-690
	C	320	600-600-600	650-650-650
	H	475-775	997-1192-342	1342-1622-1700
NOISE LEVELS	51 dB	53 dB	58 dB	
DRYER WEIGHT	24-31 kg	52-64-72 kg	77-86-107 Kg	

EDB_21_22_23

TABLE 4 - SPARE PARTS

NOTICE: Specify the machine Serial Number and the year of purchasing when applying for spare parts.

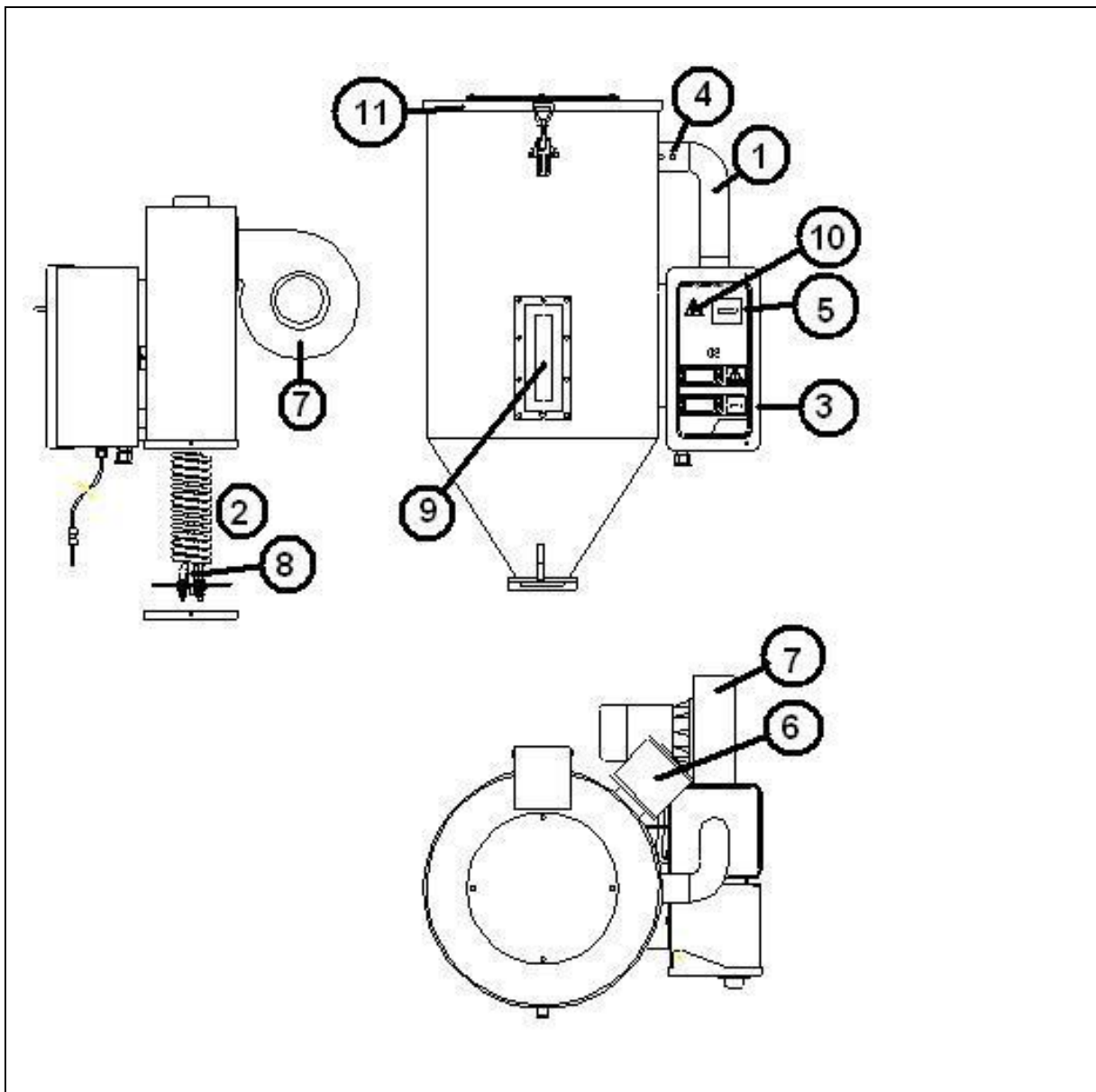

SPARE PARTS FOR HOPPER DRYERS	
N°	DESCRIPTION
1	RED PIPE
2	SPIRAL RESISTANCE
3	THERMOREGULATOR
4	DRILL PT100
5	MAIN SWITCH
6	FILTER
7	FAN (MOTOR)
8	THERMOSTAT
9	LED OF BOROSILICATE GLASS
10	DAILY/WEEKLY PROGRAMMING DEVICE (optional)
11	RED SEAL OF SILICON

OPERATION MANUAL

TABLE 5 - OPERATING DIAGRAM

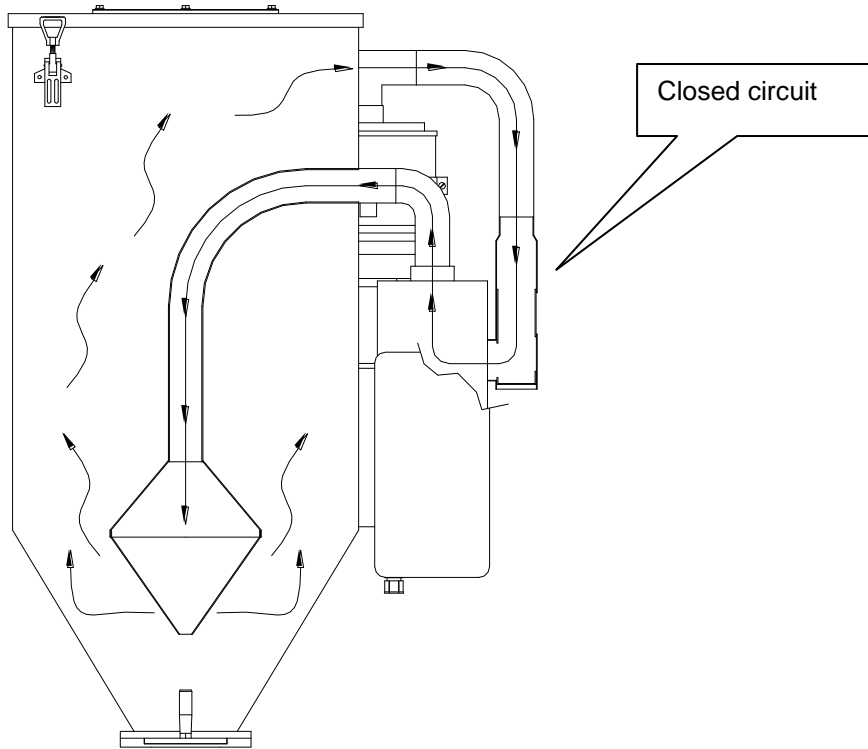
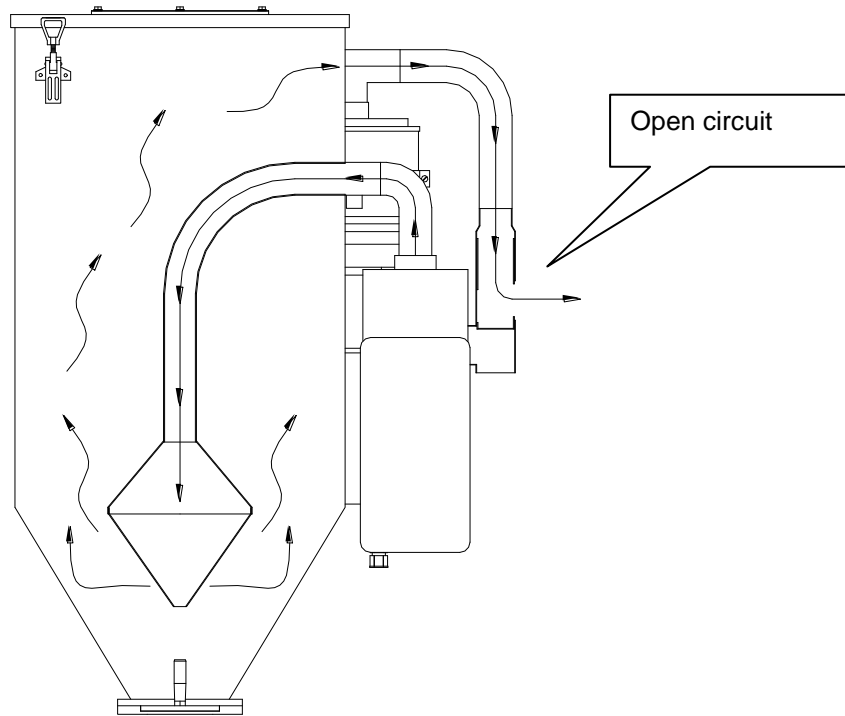

EDB_21_22_23

TABLE 6 - INSTALLATION EXAMPLES

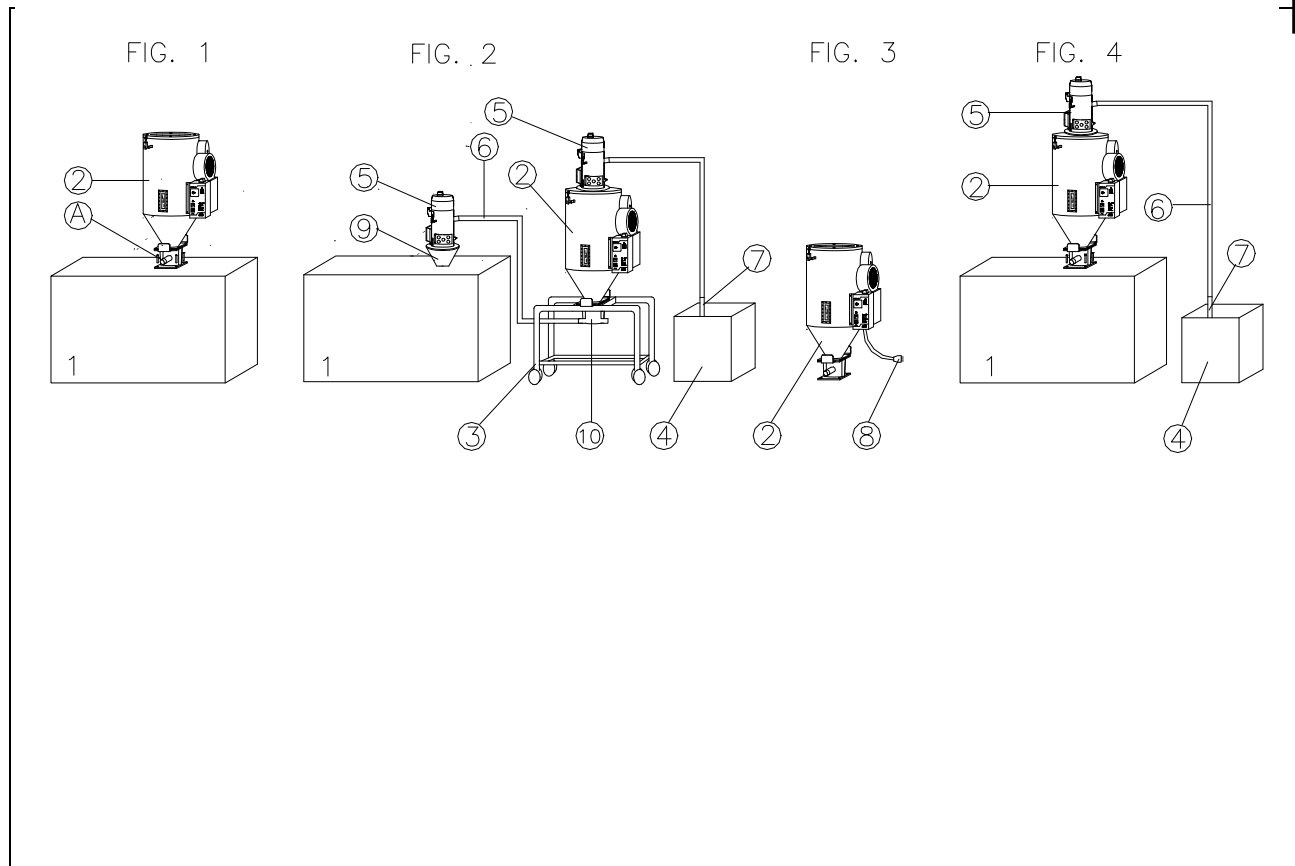

1	MOULDING PRESS OR EXTRUSION SCREW
2	DRYERS EDB21 – EDB22 – EDB23
3	TRANSFER CAR
4	MATERIAL CONTAINER
5	FSB OR FTB ADAPTER
6	FLEXIBLE PIPES
7	DRILL
8	POWER SUPPLY OUTLET 220V / 50Hz
9	HOPPER
10	INTAKE VALVE

OPERATION MANUAL

TABLE 7 - ELECTRICAL DIAGRAMS

EDB 21

4IN PRESENZA DI P2, SOSTITUIRE IL CANTANTO DI P1 QUITZ CON P2 QUITZ

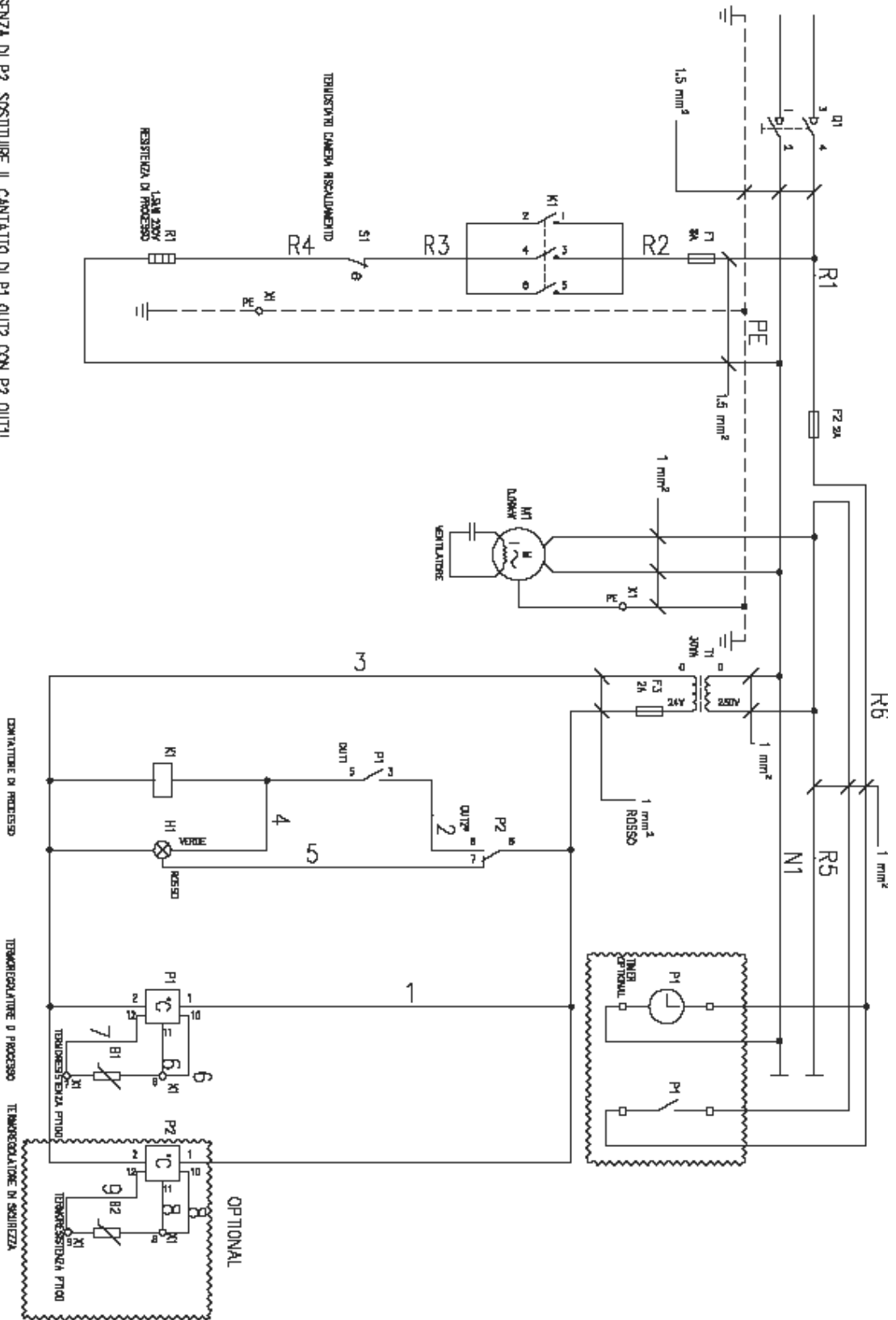

EDB_21_22_23

EDB 21

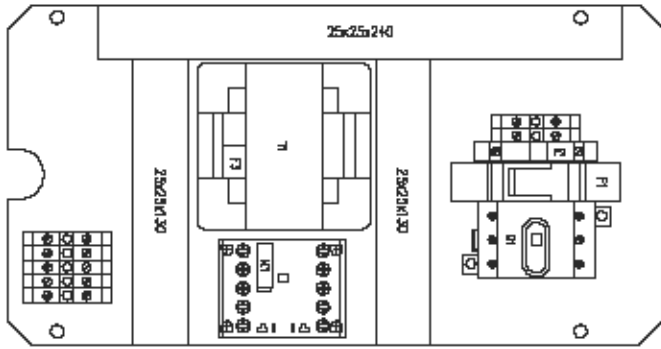

LEGENDA SIMBOLI

Simbolo	Descrizione
	Terra
	Lampada di segnalazione
	Termoregolatore
	Fusibile
	Bobina di comando contattori
	Interruzione al manovra-sezionatura
	Contattore (contatto di chiusura)
	Contatto di apertura, sensibile alla temperatura
	Contatto di scambio con interruzione nonritorna
	Contatto di chiusura
	Trasformatore monofase a due avvolgimenti con schermo
	Motore asincrono trifase, con rotore in corto circuito
	Elemento meccanico
	Terminale a nervetto (K03C012)

Simbolo	Descrizione	Note	Posizione
R1	TERMOREGOLATORE PIU00		V/507
R2	TERMOREGOLATORE PIU00		V/508
R1	RISERVA PROTEZIONE R1	RA	V/502
R2	RISERVA PROTEZIONE R1 E T1	RA	V/503
R3	RISERVA PROTEZIONE ALESTAW	2A	V/505
K1	CONDUTTORE DI PROTEZIONE	SIEMENS	V/505
M1	VENTILATORE	0.05kW	V/504
P1	OUT1*	USCITA CALORE	V/505
P1	TEMPERATURA DI PROCESSO	USCITA ALARME	V/505
P1	TEMPERATURA DI PROCESSO	PROSS AIR-110	V/507
P2	TEMPERATURA DI SPIRACOLA	PROSS AIR-110	V/508
Q1	SEMPREVERDE - INTERRUZIONE GENERALE	10A	V/501
R1	RESISTENZA DI PROCESSO	1.8kW 230V	V/502
R1	TEMPERATO CAMERA RISCALDAMENTO SPO.50°C		V/502
T1	TRASFORMAZIONE MONOFASE	310VA	V/503

*IN PRESENZA DI P2, SOSTITUIRE IL CONTATTO DI P1 CON IL COM P2 QUATTRO

OPERATION MANUAL

EDB 22_23

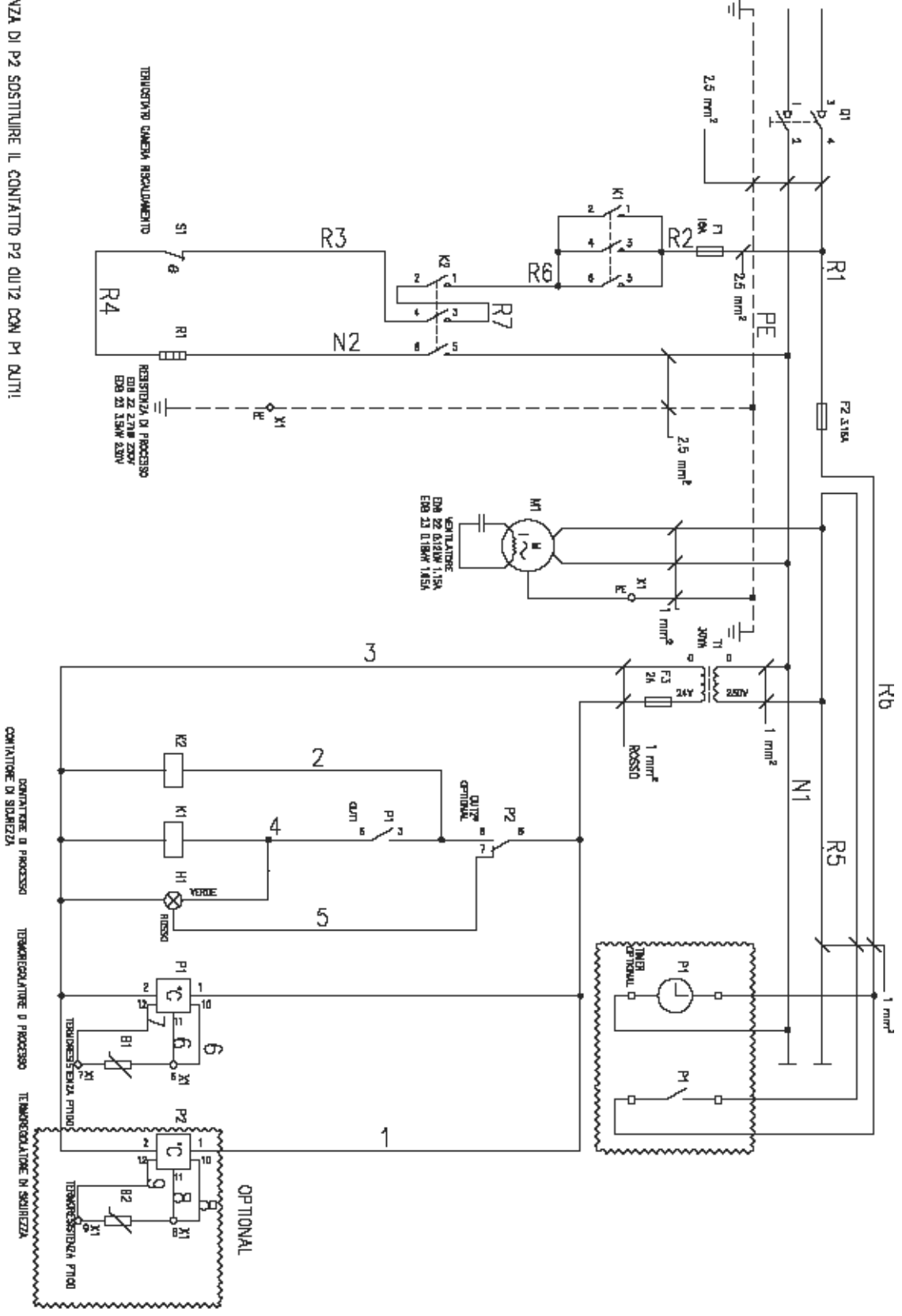

4N ASSENZA DI P2 SOSTITUIRE IL CONTATTO P2 QUITZ CON P1 DUTTI

EDB_21_22_23

EDB 22_23

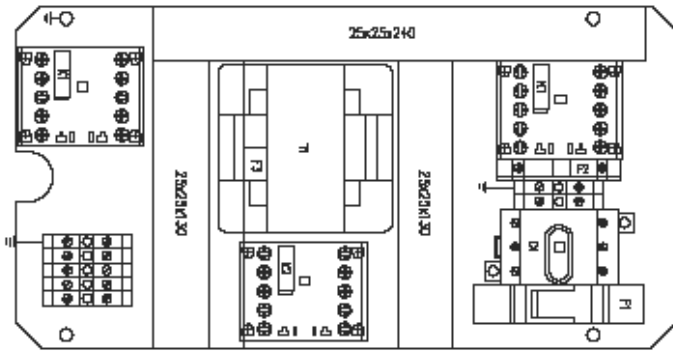

LEGENDA SIMBOLI

	Terra
	Lampada di segnalazione
	Termo-oggettore
	Fusibile
	Giunzione di contatto contatti
	Interruttore di manovra-sezionatore
	Contattore (contatto di chiusura)
	Contatto di apertura, sensibile alla temperatura
	Contatto M scambio con interruzione momentanea
	Contatto di chiusura
	Trasformatore monofase a due avvolgimenti con esterno
	Motore asincrono monofase, con rotore in corto circuito
	Elemento miscelatore
	Terminale o morsetto (0302010)

Simbolo	Descrizione	Note	Posizione
B1	TERMORESISTENZA PT100		V/507
B2	TERMORESISTENZA PT100		V/508
F1	FUSIBILE PROTEZIONE RI	10A	V/502
F2	FUSIBILE PROTEZIONE UI E TI	2A	V/503
F3	FUSIBILE PROTEZIONE ALETTURA	2A	V/505
K1	CONTATTORE DI PROTEZIONE	30A/10S	V/505
K2	CONTATTORE DI SICUREZZA	30A/10S	V/506
M1	VENTILATORE A SECONDA DEL MODELLO	ES02-21	V/504
P1	DAI	USCITA DAVANZO	V/505
P1	DAI	USCITA ALIANT	V/506
P1	TERMOREGOLATORE DI PROCESSO	RODAS AIR-110	V/507
P2	TERMOREGOLATORE DI SICUREZZA	RODAS AIR-110	V/508
Q1	SEZIONATORE-INTERRUTTORE GENERALE	21A	V/501
R1	RESISTENZA DI PROCESSO	ES02-23	V/509
S1	TERMOSTATO CALDAIA RISCALDAMENTO SCL-2010C		V/512
T1	TRASDUTTORE MOMENTANE	30A	V/505

*IN ASSENZA DI P2 SOSTITUIRE IL CONTATTO P2 DAI CON P1 DAI