

BELT CONVEYOR HL/2 Series

User and maintenance manual



DECLARATION OF CONFORMITY CE

In conformity with the 2006/42/CE Machine Directives, Enclosure II, section A

The company:

VIRGINIO NASTRI S.r.l.
Via Seconda Strada, 161 - Z.I. - 36071 ARZIGNANO (VI) ITALY
Tel. +39 - 0444 450 620 - 451 520
Fax +39 - 0444 671 840

declares under its own responsibility that the machine described below:

Driven conveyor belt suitable for parts evacuation from operating machines
Type / Item name: **Conveyor belt Mod. HL/2**
Serial number: **24790/15**
Year of production: **2015**

is in conformity with the essential safety requirements dictated:

- **Machines Directive 2006/42/CE**
- **EMC 2004/108/CE**
- **LVD 2006/95/CE**

The following harmonised norms have been applied:

EN 50081 - 2 Electromagnetic compatibility – Generic emission standard - Industrial environment
EN 50082 - 2 Electromagnetic compatibility – Generic immunity standard - Industrial environment

The signer of the declaration is:

Surname: **Virginio**
Name: **Domenico**
Position in the company: **PRESIDENT of VIRGINIO NASTRI S.r.l.**
Place and date: **Arzignano, 04/02/2015**
Signature: 

Authorizes to issue the final instruction manual:

Surname: **Virginio**
Name: **Matteo**

INSTRUCTION MANUAL INDEX

Introduction

P.1	Machine Data.....	4
P.2	How To Use And Conserve The Instruction Manual	4
P.3	Safety Warnings	5

Section A

A.1	Authorised Machine Use	6
A.2	Information On Residue Risks	6
A.3	Reference Standards And Provisions	6

Section B

B.1	Machine Technical Description And Layout.....	7
B.2	Commands	8
B.3	Regulations	8
B.4	Transportation And Installation.....	9

Section C

C.1	Maintenance Instructions.....	10
C.2	Plates And Warnings	12
C.3	Spare Parts	13
	PNL.....	14
	GAM.....	15
	SMI.....	16

Optionals

O.1	Pallet Separator
O.2	Roll Separator
O.3	Double Roll Separator
O.4	Spiral Separator
O.5	Side Seals
O.6	Electric Panel
O.7	Inverter
B.2	Commands

INTRODUCTION

P.1 MACHINE DATA

Manufacturer:

VIRGINIO NASTRI S.r.l.
 Via Seconda Strada, 161 - Z.I. - 36071 ARZIGNANO (VI) ITALY

Technical data of the HL series belt conveyor

SERIES	HL/2
Electric supply voltage	380/440 V 50/60 Hz
Installed power (kW)	0.22
Noise level at the user's position dB(A)	< 70
DIMENSIONS AND MASS	
Length (mm)	1600
Useful width (mm)	370
Total mass (Kg)	80

For technical assistance and information:

VIRGINIO NASTRI S.r.l.
 Via Seconda Strada, 161 - Z.I. - 36071 ARZIGNANO (VI) ITALY
 Tel. +39 - 0444 450 620 - 451 520
 Fax +39 - 0444 671 840

N.B.: The user instruction manual is an integral part of the machine itself. Knowledge of the points contained in this manual is essential for safe machine use. This booklet is the Instruction Manual of the previously identified machine and was compiled in accordance with the 2006/42/CE Directive, Annex I, para. 1.7.4

P.2 HOW TO USE AND CONSERVE THE INSTRUCTION MANUAL

This instruction manual describes machine use as forecasted by design hypothesis, supplies information on how to transport, use, carry out maintenance on and dismantle the machine, and also how to order spare parts.

The instruction manual is a part of the machine and must be kept “for future reference” until final dismantling. It must be conserved in the most opportune manner in the place where the belt is used, and must always be easily reachable.

This manual mirrors the technical state of the machine at the machine marketing date.

VIRGINIO NASTRI S.r.l. reserves the right to update production and manuals without the obligation to update previous production and manuals.

A new manual can be requested if the one supplied with the machine is lost or damaged, or if another copy is necessary. When requesting a new copy, please refer to the data given on the CE plate which can be found on the machine.

P.3 SAFETY WARNINGS

In order to ensure maximum working reliability, VIRGINIO NASTRI S.r.l. accurately selects the materials and components used to produce the machine, and regularly tests it before shipment. Good machine return through time depends on correct use and suitable maintenance, in accordance with the instructions indicated in this manual.

All the construction elements, as well as the connection and command organs, have been designed and produced with a safety level that permits resistance to stress that is abnormal or at least above those levels indicated in this manual. The materials are of the best quality and their entry into the company, storage and use is constantly controlled in order to guarantee the absence of damage, deterioration and malfunctions.

It should, however, be remembered that:

- 1) THE MACHINE MUST NOT BE USED NOR INTERVENTIONS CARRIED OUT ON IT IF THIS MANUAL AND ALL ITS PARTS HAVE NOT BEEN FULLY READ AND UNDERSTOOD.
- 2) IT IS NECESSARY TO USE ALL THE PRECAUTIONS LISTED IN SECTION A: “SAFETY PRESCRIPTIONS AND INFORMATION”.
- 3) IT IS FORBIDDEN TO USE THE MACHINE IN CONDITIONS OR MANNERS THAT ARE DIFFERENT FROM THOSE INDICATED IN THE MANUAL. VIRGINIO NASTRI S.r.l. CANNOT BE HELD RESPONSIBLE FOR FAULTS, INCONVENIENCES OR INJURY CAUSED BY THE NON-OBSERVANCE OF THIS POINT.

This manual has been divided into three parts:

- | | |
|------------|---|
| SEZIONE A. | which looks at “SAFETY PRESCRIPTIONS AND INFORMATION” |
| SEZIONE B. | in which the MACHINE CHARACTERISTICS – OPERATION – TRANSPORTATION aspects are indicated |
| SEZIONE C. | which describes the MAINTENANCE AND LUBRICATION INTERVENTIONS with an annexed LIST AND DESCRIPTION OF THE SPARE PARTS |

To make reading easier, the following terms have been used:

DANGER

The term DANGER is used in situations where not respecting the regulations or tampering with organs can cause serious injury to people.

ATTENTION

The term ATTENTION is used in situations where not respecting the instructions can damage the machine or other elements associated with it or the surrounding environment.

SECTION A

General information for using the machine safely

A.1 AUTHORISED MACHINE USE

This series of belt conveyors should be used for collecting and transporting plastic parts coming from moulding machines and going towards the accumulation area.

The belt run can be varied and the following adjustments are possible:

- adjustment of conveyor's height
- adjustment of conveyor's inclination

ATTENTION:

The maximum weight of the transportable parts must not exceed 70 Kg in total. The belts are not suitable for transporting loose material.

The belt conveyors can be easily used by all the staff of the plant in which it is installed, and if used correctly does not present any risks for the operator.

We recommend reading this manual, however, before using the machine.

VIRGINIO NASTRI S.r.l. declines any responsibility in the following cases:

- if the belts are used in evident contrast to the manner indicated in this instruction booklet
- if there are supply faults
- if the necessary maintenance is not carried out as indicated
- if unauthorised modifications are made
- if unauthorised spare parts or spare parts that are not specifically for the model are used
- in cases of exceptional events

A.2 INFORMATION ON RESIDUE RISKS

Residue risk: a risk that remains in spite of all the precautions adopted, or a potential risk that is not evident (Directive 2006/42/CE/ para. 1.7.2.).

This series of belt conveyors basically does not present residue risks for the operator, as long as the instructions given in this manual are followed. In spite of this, however, the following indications are valid according to usage conditions:

DANGER:

Risk of fire: fire can break out if the characteristics of the belt used are not suitable for belt use (in particular: the temperature of the pieces to be transported).

Make sure, therefore, that the type of material used for the transporting surface has adequate characteristics. Refer to the data given in the following table.

	CODE	MATERIAL	TEMPERATURE MAX
<input type="checkbox"/>	2M12 U0-U3 P347C	GREEN PU	100° C
<input type="checkbox"/>	2M8 U0-V5 P347C	GREEN PVC	60° C
<input checked="" type="checkbox"/>	2M8 U0-V5 P347C	PVC BLUE	60° C

Risk of elevated temperatures: the belt should be used to transport pieces that have just been moulded, therefore which are hot. Should it be necessary to intervene, use protective gloves (particularly in the piece falling area).

A.3 REFERENCE STANDARDS AND PROVISIONS

- This belt conveyor series was designed and produced to satisfy the Essential Safety requirements as dictated by the 2006/42/CE Directive, Annex I.
- Reference is made to the EN 60204-1 Standard, September 1993 edition, for electric equipment.

SECTION B

Information on belt use

WARNING: Before reading this section you must be familiar with what is indicated in section A, an integral part of the user manual and which must be understood for using the machine SAFELY.

B.1 MACHINE TECHNICAL DESCRIPTION AND LAYOUT

This belt conveyor series is made up of:

A load bearing frame of folded sheet aluminium (1). There are containment projections on the sides (2), and everything is supported by the supplied rods (3). The rods can be adjusted as follows:

- Use the screws (4) to regulate the inclination;
- Remove the screws (5) and use the legs (6) to regulate the height;

There are casters with a locking device (7) on the base, which makes it possible to move the belt around the working area.

The belt conveyor frame has some supports (8) which hold a drum (9) that rotates. This drum is moved directly by a gearmotor (10), which in turn moves the belt (11) forward. The return drum (12) rotates as a consequence of belt movement.

The noise level issued by the machine at the operator's working place is < 70 dB(A).

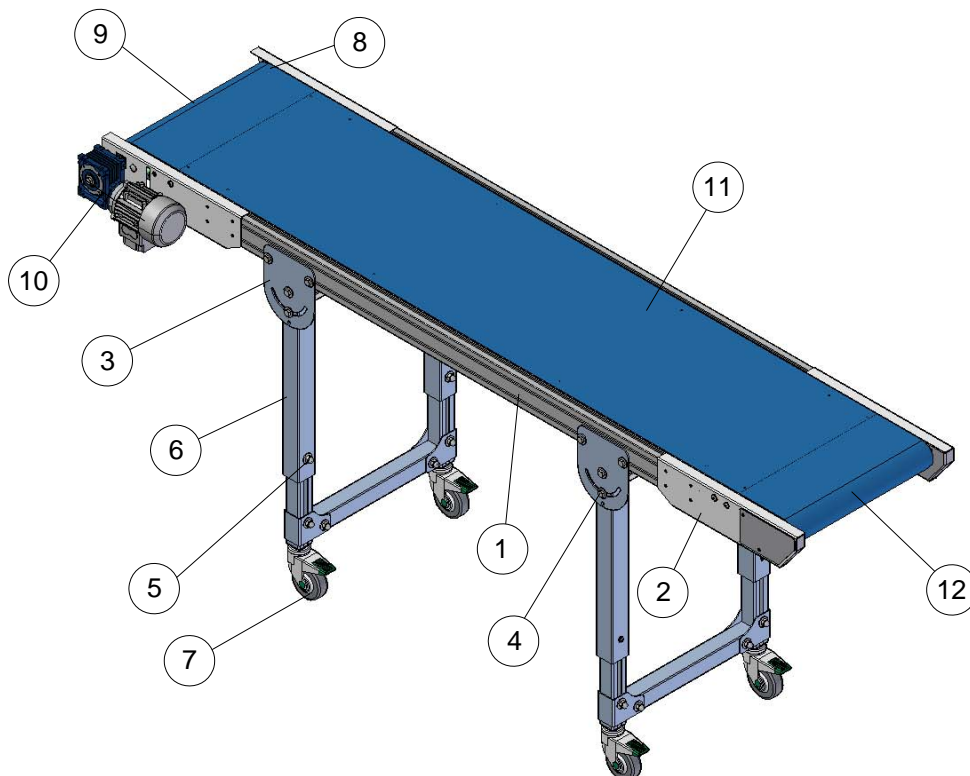

B.2 COMMANDS (OPTION)

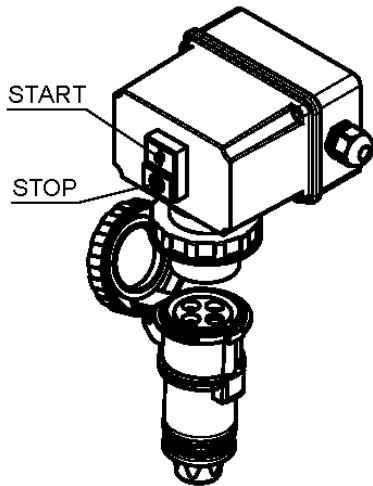

Pic. A

As described in the previous paragraph, the switch with the belt start and stop keys is positioned in the discharge area (Pic. A).

Emergency stop: whenever necessary, directly disconnect the belt supply plug.

B.3 REGULATIONS

Regulating the height of the belt (Pic. B)

ATTENTION:

This operation should be carried out with at least two people working together.

Loosen the bolts (1), extract the screws (2), raise or lower the telescopic legs (3). When the correct height has been reached, insert the screws (2) and tighten the nuts (1).

Regulating the belt inclination (Pic. B)

ATTENTION:

If the lock nuts are loosened (4) the belt does not remain in equilibrium, because unbalanced by the gearmotor.

This operation should be carried out with at least two people working together. One should support and regulate the belt, the other should loosen and tighten the lock nuts (4).

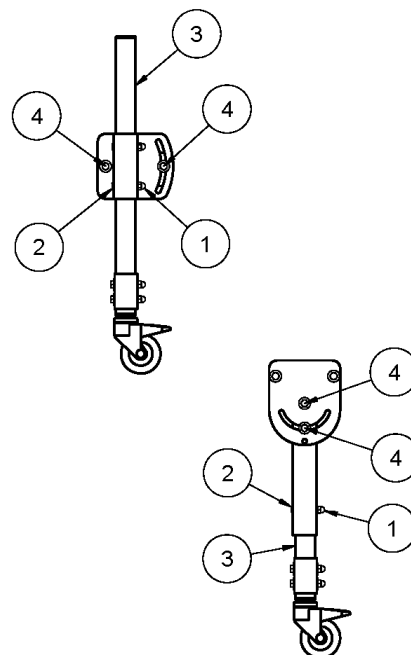

Pic. B

B.4 TRANSPORTATION AND INSTALLATION

Transportation

Stretch film is used to wrap the belt conveyors. The switch and gearmotor boxes are protected by sponge rubber.

ATTENZION

The packaging material (plastic film and sponge rubber) should not be disposed of in the environment but in accordance with current norms.

The belt conveyors should be raised using a fork lift truck. The overall dimensions and mass of the belts in this series are given in para. P1.

DANGER

For operator safety and machine integrity please refer to Pic. C, which shows where to insert the forks in order to raise the belt in a stable manner.

Once on the lorry loading surface, the machine should be fixed using levers to block the wheels. Suitable slings or fixing methods should also be prepared to ensure stability during transportation.

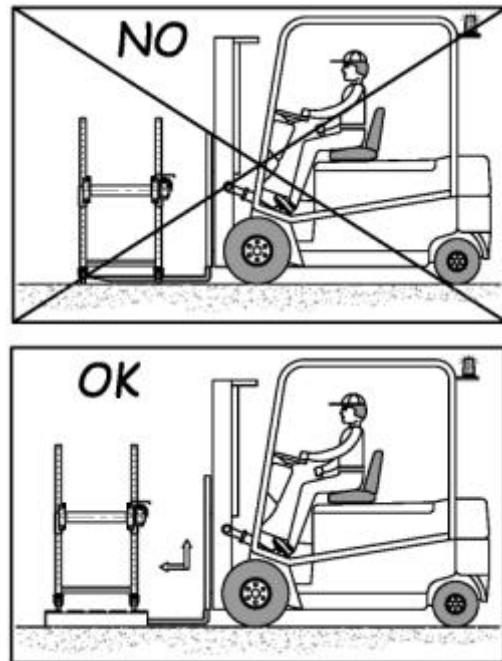

Pic. C

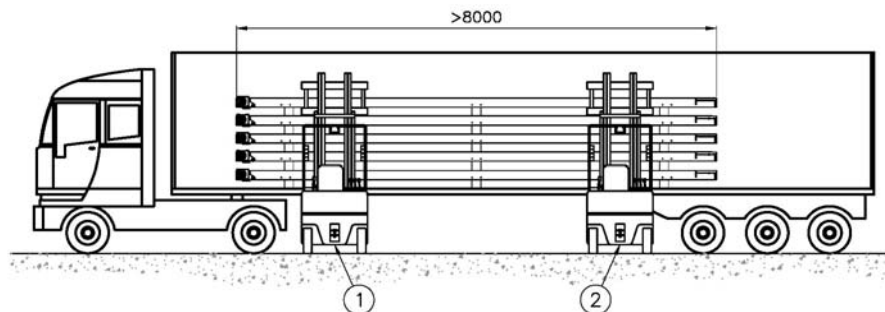

Installation

No particular preliminary operations are necessary when starting the belt conveyors for the first time.

The belt should be connected to an outlet having suitable characteristics. Use the supplied plug.

When laying the cables, please make sure that they are protected against damage and that they cannot trip the operators.

ATTENTION:

Before starting the belt conveyor:

- make sure that the supply voltage corresponds to the one indicated on the plate. The plate can be found beside the belt button
- check the correct rotational direction of the motors. Make sure that the belt rotates in the direction indicated by the arrow on the belt casing

Position the belt conveyor by inserting the lower surface opening (loading area) into the relative opening which passes under the press mould.

ATTENTION:

When the machine has been installed, the casters must be locked using the levers on each wheel.

SECTION C

Information on maintenance and repairs

C.1 MAINTENANCE INSTRUCTIONS

GENERAL NOTES

The operator must ensure that the machine is kept clean of foreign material such as deposits, oil or others.
The machine should therefore be cleaned at the end of each work shift when it has stopped and is in a stable condition.

ATTENTION:

Before starting, the operator should switch off the belt and extract the mains plug to avoid any possibility of accidental starting.

If compressed air is used to clean the machine, protective goggles with additional mask should be used. Any people in the surrounding area should also be removed to avoid the danger of being hit and injured by material and dust.

Do not use pressurised water directly on the electric apparatus.

It is forbidden to use flammable liquids for cleaning.

Periodically check the state of the plates and replace them if necessary.

Once the machine has been cleaned, the operator should make sure that there are no parts that are worn or damaged (if there are, immediately request the intervention of the maintenance technician) or parts that are not solidly fixed (do as much as possible).

The operator and possible maintenance technician must wear suitable working clothes that do not fly about, and should not wear chains or bracelets or other items which can catch easily in the moving mechanical organs. Operators with long hair should use a hairnet to prevent the risk of entanglement.

The protection and safety devices must not be removed unless a repair and/or maintenance operation is to be carried out.

These devices must be replaced as soon as the reason for their temporary removal has been corrected, and in any case before the machine is started again.

ATTENTION:

At the end of each machine intervention, use the relative levers to lock the wheels.

This belt conveyor series does not require particular maintenance operations, just some simple interventions.

Inspect to ensure that:

- the gearmotors are not leaking lubricant
- the belt is tightened correctly (*)
- the belt is centred correctly (*)
- the electric cable insulating sheath is in good condition (every 2000 working hours)

ATTENTION:

Before carrying out this operation the machine must be put out of service. In addition, the plug should be disconnected from the mains after having switched off the belt.

Should it be necessary to regulate the belt, remove the casing at the belt end and use the tension rod regulating nuts. To centre the belt, unscrew the small casing at the belt end, both on the lower part and the inclined part, then use the tension rod regulating nuts. Allow the cloth to turn until it is well centred on the drum (Pic. D).

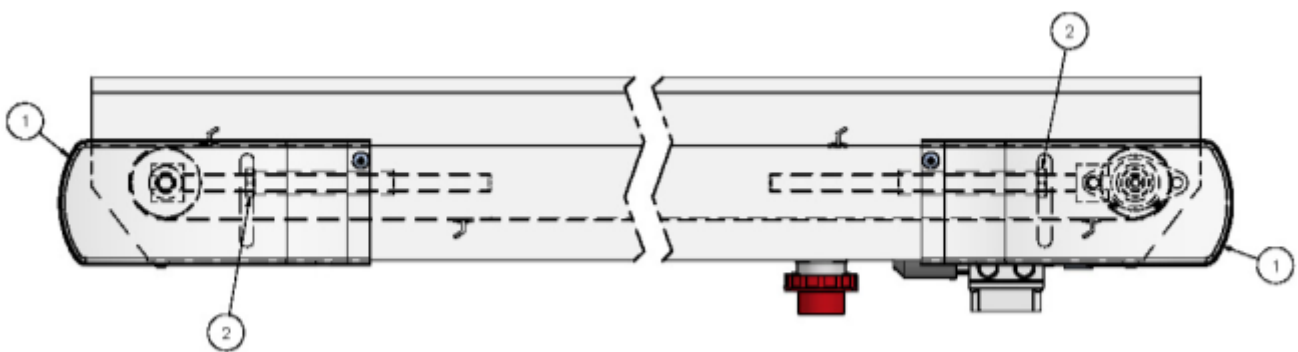

Pic. D

DANGER:

The cloth should be turned to check centring. Regulate while the machine is not moving and make the belt turn only for the time necessary for verifying correct cloth centring.

Each month, make sure that the external temperature of the motor and the gearmotor is not too high (lower than 60°C). Should irregularities occur, directly contact VIRGINIO NASTRI S.r.l. technicians.

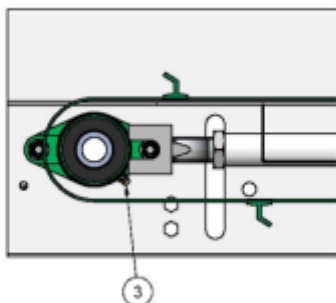

Pic. E

Lubrication:

Every month grease the two supports on the belt discharge section, under the protective casing, as indicated in the diagram (Pic. E).

C.2 PLATES AND WARNINGS

The following danger symbol is present on the wrapping of terminal boards that can be powered:



The plate shown below is also present on the belt:



C.3 SPARE PARTS

Should it be necessary to order spare parts, please refer to the address given in para. P1. When ordering, always give the part code and the requested quantity of each part ordered.

Note: Only original spare parts supplied by VIRGINIO NASTRI S.r.l. guarantee operation reliability.

It should be noted, in particular, that some components have safety characteristics for the personnel, therefore these pieces should only be replaced with the parts recommended by VIRGINIO NASTRI S.r.l.

SPARE PARTS AND RELATIVE CODES

CODE	DESCRIPTION
HL2 001	CONVEYOR'S FRAME WORK
HL2 002	TRANSMISSION TENSION BAR
HL2 003	SUPPORT
HL2 004	DRIVE ROLLER
HL2 005	TRANSMISSION ROLLER
HL2 006	BELT
HL2 007	GEARBOX
HL2 008	MOTOR
HL2 009	MOTOR PROTECTION COVER
GAM 001	SUPPORT BRACKET
GAM 002	STRENGTHENING PLATE
GAM 003	TELESCOPIC 50x50
GAM 004	PLASTIC CAP
GAM 005	JUNCTION ANGLE
GAM 006	CROSSBAR 50x50
GAM 007	SWIVEL CASTORS WITH BRAKE FACILITY
SMI 001	SUPPORT BRACKET UNDERNEATH CONVEYOR
SMI 002	TUBE 60x60
SMI 003	ALUMINUM CROSSBAR 45x45
SMI 004	TELESCOPIC 50x50
SMI 005	JUNCTION ANGLE
SMI 006	CROSSBAR 50x50
SMI 007	SWIVEL CASTORS WITH BRAKE FACILITY

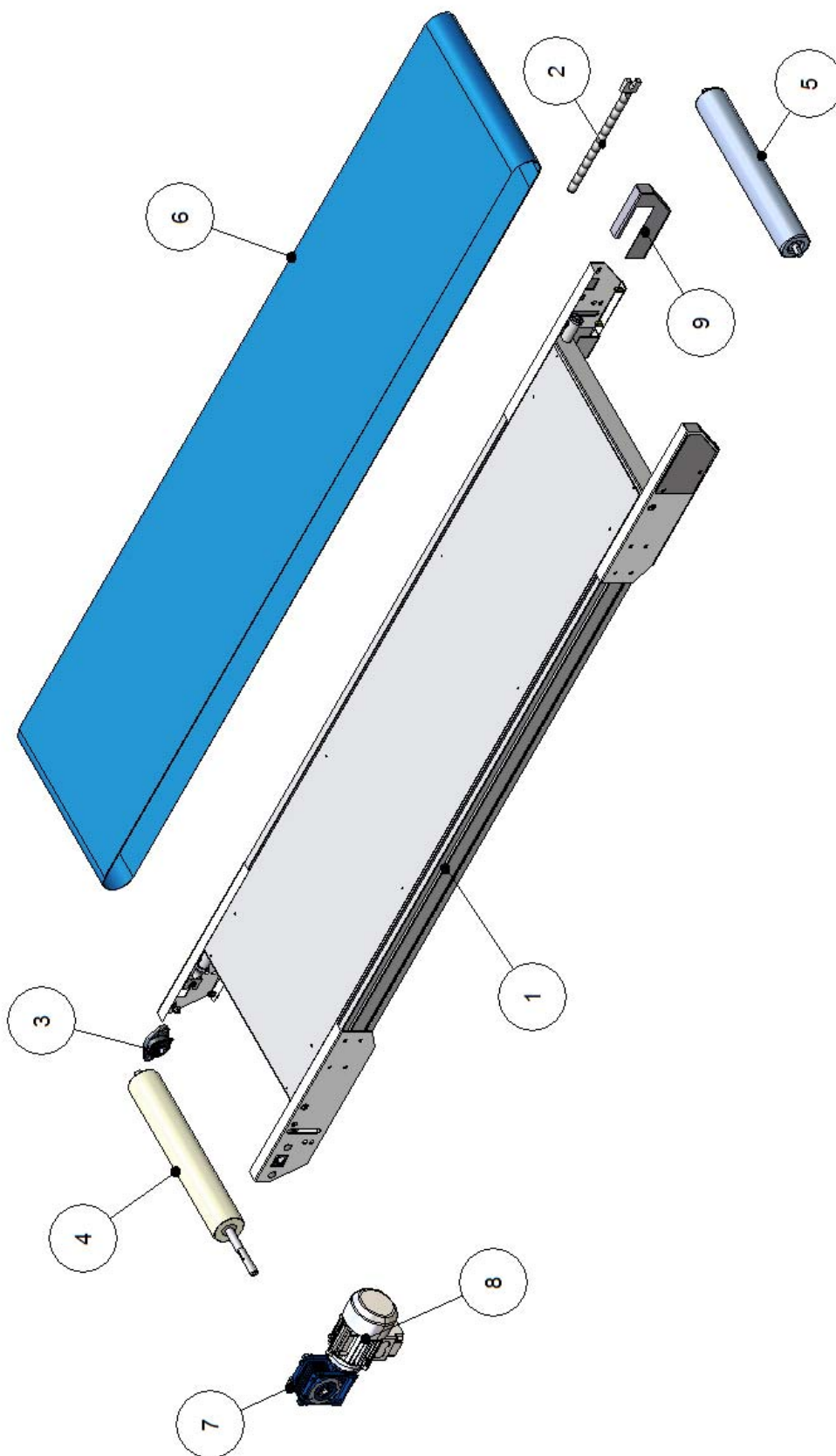

GAM

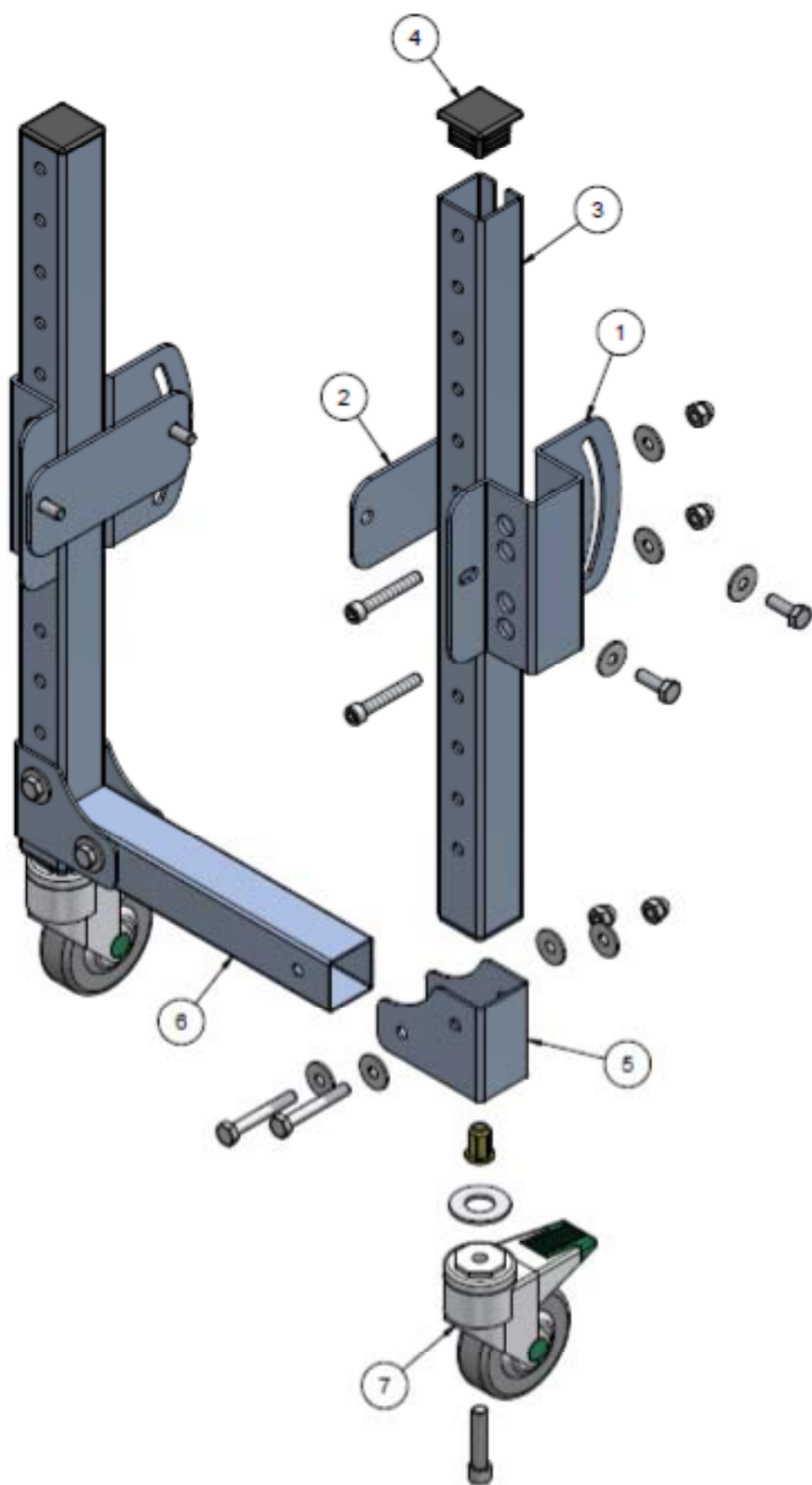

SMI

